

Electric Gripper Product Manual

Leading provider of lightweight collaborative robot arms

Main Business:

Industrial Robot

Collaborative Robot

Electric Gripper

Electric Cylinder Module

Directory

The first part Part Part Number Definition

1. Z-EFG series jaw definition.....	1
2. Specification table.....	2
3.Z-EFG-100 Detailed Parameter Table.....	3
5.Z-MOD module family definition.....	5

The second part Z-EFG-8 Detailed Parameter Table

1.Installation diagram.....	7
3.Line sequence description (NPN).....	9
5.Line sequence description (PNP).....	11
6. Gripping Force Curve.....	12
7. Gripping Force.....	19

The third part Z-EFG-12 Detailed Parameter Table

1. Installation diagram.....	14
2. Line sequence description(NPN).....	15
3. Line sequence description(PNP).....	16
4. Z-EFG-12 Electric gripper electrical parameters.....	17

The fourth part Z-EFG-20 Detailed Parameter Table

1. Installation with Wiring diagram.....	19
3.Line sequence description (NPN).....	21
5.Line sequence description (PNP).....	23
6. Z-EFG-20 Electric gripper electrical parameters.....	24

The fifth part Z-EFG-F Detailed Parameter Table

1. Installation diagram.....	26
3.Line sequence description (NPN).....	28
4. Z-EFG-F Electric gripper clamping force curve.....	29

The sixth part Z-EFG-L Detailed Parameter Table

1. Installation diagram.....	31
2. Line sequence description (NPN).....	32
4. Z-EFG-L Electric gripper clamping force curve.....	33

The seventh part Z-EFG-R Detailed Parameter Table

1. Installation diagram.....	35
3.Line sequence description (NPN).....	37
6. Z-EFG-R Electrical parameters of electric gripper.....	38

The eighth part Control board instructions

1.Control board instructions.....	40
2. Instructions for use of Electric Gripper Isolation Board wiring.....	41

The ninth part Z-EFG-100 Detailed Parameter Table

- 1. Installation diagram.....45
- 2. connection with communication protocol..... 46
- 3. register address and description.....47

Part Number Definition

Electric Gripper Z-EFG series Definition

Z-EFG-8PK-U-FXXX-01

EFG: 2 refers to the translational electric claw
 ECG: Finger slider electric claw
 EMG: Electromagnetic electric claw

8: 8mm trip
 20: 20mm trip
 12: 12mm trip
 100: 90mm trip
 F: 8mm Upgraded version of the stroke six axis manipulator
 R: 20mm Upgraded version of the stroke six axis manipulator
 L: 12mm Upgraded version of the stroke six axis manipulator

Communication methods:
 NK: Standard NPN type IO control
 NM: Standard NPN pulse control
 PK: Standard PNP IO control
 PM: Standard PNP pulse control
 NMA: N - pn pulse control electrical static
 PMA: PNP pulse control on-powerstaticTXA:485 communication

F: Non-standard customization options, if the standard, is empty
 XXX: Customer label
 01: The version number

Cable outlet mode:
 HCA: 5 core aviation plug male head (M12)
 HCB: 4 core aviation plug male head (M8)
 HW: Rubber tail card
 HQ: To protect the coil
 U: UR version outgoing (plug + Lombard wire)
 A: AUBO version outgoing (plug + Lombard wire)
 E: ELITE version outgoing (plug + Lombard wire)
 Z1: Outgoing line used with HITBOT 1632 (unshielded line)
 Z2: Outgoing line used with HITBOT 2140 (unshielded line)

Note: except in the case of special instructions (as in the case of Hitbot above), all shielding wires are provided

Specification table

Parameter	Z-EFG-8	Z-EFG-F	Z-EFG-12	Z-EFG-L	Z-EFG-20	Z-EFG-R
Total stroke	8mm		12mm		20mm	
Clamping force	5-30N		30N		80N	
Max clamping weight	≤300g		≤500g		≤500g	
Repeated positioning accuracy	/		/		±0.02mm	
Mode of motion	Two-finger translation					
Adjusting of stroke	Non-adjustable				Adjustable	
Adjusting of clamping force	Adjustable		Non-adjustable		Adjustable	
Weight	0.235kg		0.342kg		0.458kg	
Closing or Opening time	0.3s		0.2s		0.45s	

Dimensions (L*W*H)	30*24*94mm		48*32*105.6*mm		44*30*124.7mm	
Placement mode of controller	Built-in controller					
Power	3.6W			5W		
Motor type	BLDC				Servo	
Rated voltage	1A					
NPN gripper	<p>Output connection of Z-EFG-8 NPN gripper directly connected controller</p> <p>Recommend types:</p> <p>①NPN Type output</p> <p>②3.3V/5V Push-pull output</p> <p>③NPN Type pull-up output</p> <p>3.3V/5V/24V Z-EFG-8 NPN Output signal types:</p> <p>3.3V Push-pull output, internal connect in series 1K resistance current-limiting protection.</p>		<p>Output connection of Z-EFG-12 NPN gripper directly connected Controller</p> <p>Recommend types:</p> <p>①NPN Type output</p> <p>②24V Push-pull output</p> <p>③NPN Type pull-up output</p> <p>24V Z-EFG-12 NPN Output signal types:</p> <p>PNP type output or NPN type output (optional), default to the PNP output.</p>		<p>Output connection of Z-EFG-20 NPN gripper directly connected controller</p> <p>Recommend types:</p> <p>①NPN Type output</p> <p>②3.3V/5V Push-pull output</p> <p>③NPN Type pull-up output</p> <p>3.3V/5V/24V Z-EFG-20 NPN Output signal types:</p> <p>3.3V Push-pull output, internal connect in series 1K resistance current-limiting protection.</p>	
PNP gripper	<p>Output connection of Z-EFG-8 PNP gripper directly connected controller</p> <p>Recommend types:</p> <p>①24V PNP Type output</p> <p>②24V Push-pull output</p> <p>Z-EFG-8 PNP Output signal types:</p> <p>PNP Type pull-up output 24V, the pull-up resistance is 2.2K.</p>		<p>Output connection of Z-EFG-12 PNP gripper directly connected controller</p> <p>Recommend types:</p> <p>①24V PNP Type output</p> <p>②24V Push-pull output</p> <p>Z-EFG-12 PNP Output signal types:</p> <p>PNP type output or NPN type output (optional), default to the PNP output.</p>		<p>Output connection of Z-EFG-20 PNP gripper directly connected controller</p> <p>Recommend types:</p> <p>①24V PNP Type output</p> <p>②24V Push-pull output</p> <p>Z-EFG-20 PNP Output signal types:</p> <p>PNP Type pull-up output 24V, the pull-up resistance is 2.2K.</p>	
Flange connection	/	UR robotic arm flange	/	UR robotic arm flange	/	UR robotic arm flange
UR driver	Invoked with Urcap libraries directly.					

■ ■ Z-EFG-100 Detailed Parameter Table

Parameter	Z-EFG-100
Total stroke	90mm
Clamping force	35-60N
Max clamping weight	500g
Repeated positioning accuracy	± 0.02mm
Closing or Opening time	1s

Operating temperature range	5-55°C
Adjustable stroke	Adjustable
Adjustable clamping force	Adjustable
Weight	925g
Dimensions	204*138.5*45(Open) 222*79*45 (Close)
Placement mode of controller	Built-in controller
Power	30W
Rated voltage	24V

■ ■ Z-MOD module family definition

Z-Mod-KK -82 -20SE-10-200-C7-S1-N1-DP -N -FXXX-01

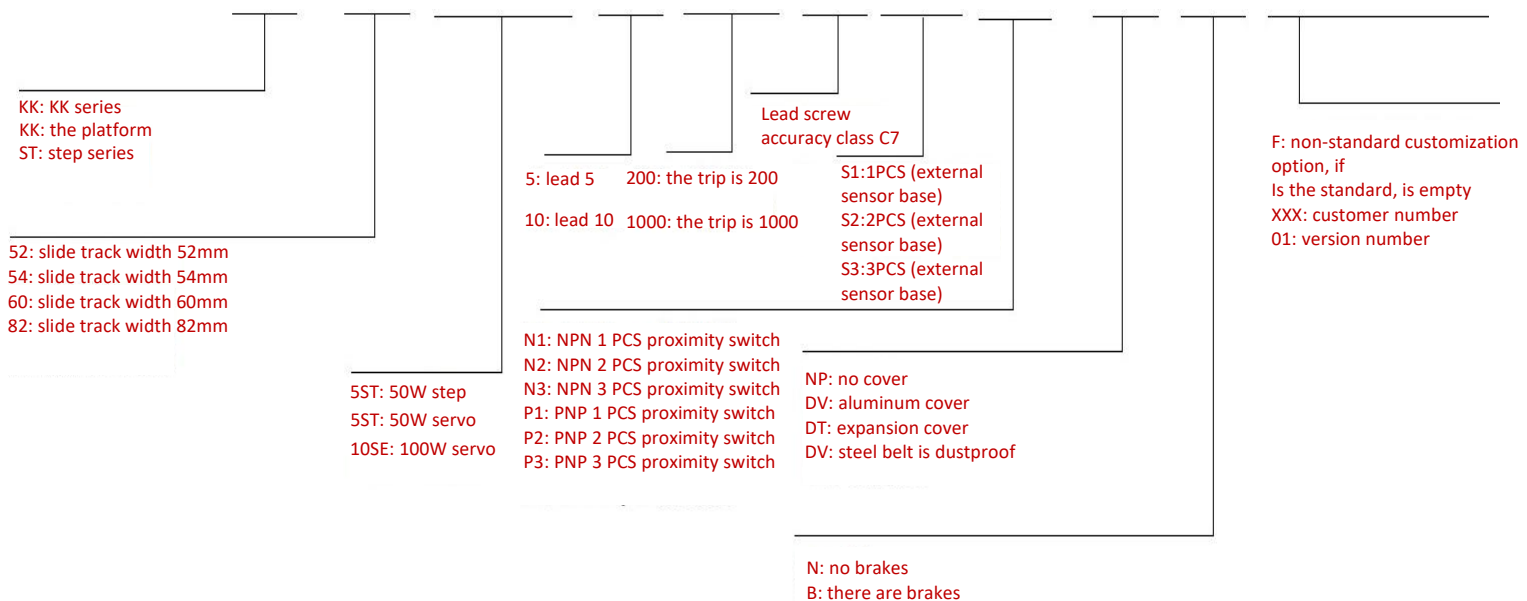

■ ■ ■ Z-EFG-8 Detailed Parameter Table

Items	Z-EFG-8
Total Travel (Effective)	8 mm
Gripping force	5-30 N
Maximum gripping weight	≤300 g
Repeated positioning	/
Motion components	Cross roller guide rail + rack and pinion
Oil supply for moving parts	Every six months or one million moves/time
Shock/shock resistance	98 m/s ²
Operating temperature	5~55 °C
Operating humidity range	RH35-80 (No frost)
Mode of movemen	Two-finger translation
Travel adjustable	Not adjustable
Gripping force adjustable	adjustable
Body weight	0.235 kg
Size specification	30*24*94 mm
Controller placement	Built - in
power	3.6 W
Motor type	DC brushless
The motor diameter	17 mm
Rated voltage	24 V
Standby current	≤0.02A



Z-EFG-8 Installation diagram

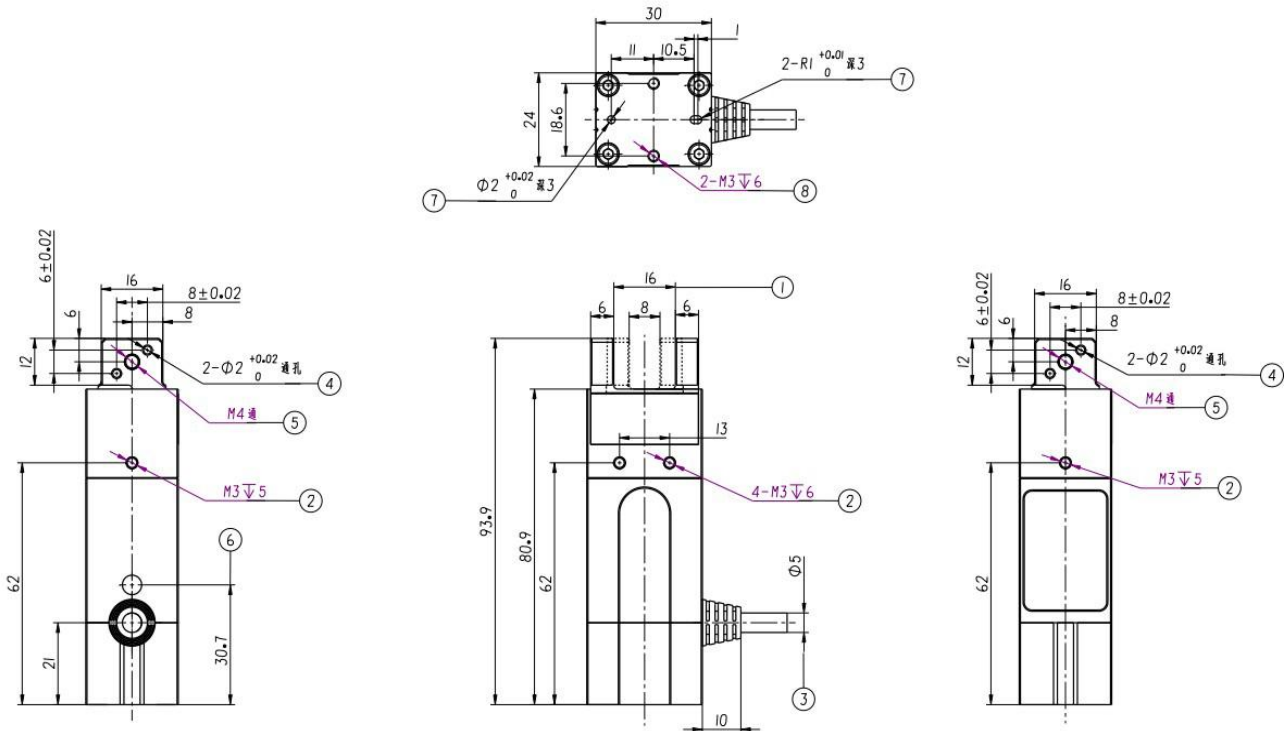

1. Movement stroke of gripper fingers
2. Side mounting position (threaded hole)
3. Control Line
4. Fixture mounting position (pin hole)
5. Gripper mounting Position (Threaded Hole)
6. Gripping force adjustment place

Z-EFG-8 Wiring diagram

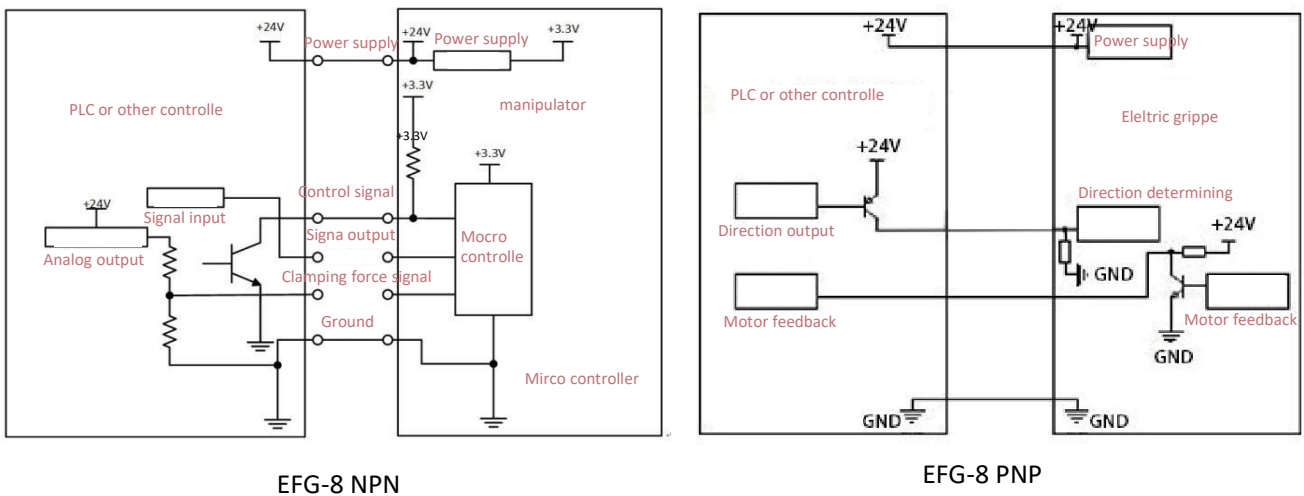

■ ■ Z-EFG-8 Line sequence description (NK)

linetype	Function	Description	Remarks
Red line	24V	Power supply	Must be connected
Black line	GND	Power supply	Must be connected
Green line	Control Signal (Opening Or Closing)	<p>If the logic level of the controller is 3.3V or 5V, the I/O port can be directly connected</p> <ul style="list-style-type: none"> ● When 0V-0.7V is input (low level), the electric gripper open ● When 2.7V-5V is input (high level), the electric gripper close <p>If the logic level of the controller is higher than 5V, Open Drain output can be used(Open Drain)</p> <ul style="list-style-type: none"> ● When the drain is open and the output is Open Drain (invalid), the electric gripper is closing ● When 0V-0.7V is input (valid), the electric gripper open <p>If the logic level of the controller is higher than 5V, and the second method cannot be used. (A resistor can be connected in series, and the resistance value is 8.2k when the single control voltage is 24V)</p> <ul style="list-style-type: none"> ● When the input is higher than 2.7V (high level), the electric gripper clamps inward ● When 0-VLow* is input (low level), the electric gripper opens to the outside 	Must be connected
White line	gripping force analog signal input	<ul style="list-style-type: none"> ● May not connect * ● During connection, it is used to continuously adjust the gripping force, input 0.5~2.7V, and output 5-30N corresponding to the gripping force. The higher the input value, the greater the gripping force. 	Select connection
Yellow line	Feedback Signal	<ul style="list-style-type: none"> ● May not connect, read-only signal, display LED status ● Output 0V when moving, output 3.3V at the end of moving 	Select connection

* Explanation

1. When the white line is not connected, the gripping force is controlled by potentiometer. When the white line is connected, the gripping force is controlled by white line signal
2. The potentiometer is located above the connector on the side of the electric gripper
3. When leaving the factory, the potentiometer defaults to a vertical state. If the white line is not connected at this moment, the gripping force is 20N, which is increased clockwise and decreased counterclockwise (vertical is 0, counterclockwise is negative, clockwise is positive)
4. 30N for +60°, 5N for -60°
5. Please do not rotate the potentiometer to the maximum or minimum position ($\pm 62.7^\circ$, when the potentiometer is at the maximum or minimum position, the electric gripper will be in a protected state (stationary))
6. $V_{Low} \leq 0.7 - 2.6 \cdot R_x / 50K$

■ ■ Z-EFG-8 Line sequence description (PK)

linetype	Function	Description	Remarks
Red line	24V	Power supply	Must be connected
Black line	GND (0V)	Power supply	Must be connected
Green line	Control Signal (Control Clamp or Release)	<p>If the logic level of the controller is 24V, it can be directly connected to the I/O port</p> <ul style="list-style-type: none"> When 0V-0.7V is input (low level), the electric gripper opens to the outside When 18V-24V is input (high level), the electric gripper clamps inward <p>If the logic level of the controller is 24V PNP, it can be directly connected to the I/O port</p> <p>If the controller output is NPN type, the I/O port needs to be pulled with a 4.7K resistor (external) to 24V</p>	Must be connected
White line	Not in use	/	/
Yellow line	Feedback Signal	<ul style="list-style-type: none"> May not connect, only read signal, display LED status Output 24V when moving (internal pull-up 4.7K resistor to 24V) and 0V at the end of the movement 	Select connection

* Explanation

- The grasping force is controlled by potentiometer
- The potentiometer is located above the connector on the side of the electric gripper
- When leaving the factory, the potentiometer defaults to a vertical state, the gripping force is 20N, which is increased clockwise and decreased counterclockwise (vertical is 0, counterclockwise is negative, clockwise is positive)
- 30N for +60°, 5N for -60°
- Please do not rotate the potentiometer to the maximum or minimum position ($\pm 62.7^\circ$). When the potentiometer is at the maximum or minimum position, the electric gripper will be in a protected state (stationary)

■ ■ Z-EFG-8 Gripping Force Curve

Different voltage inputs pass through white lines and output different gripping forces

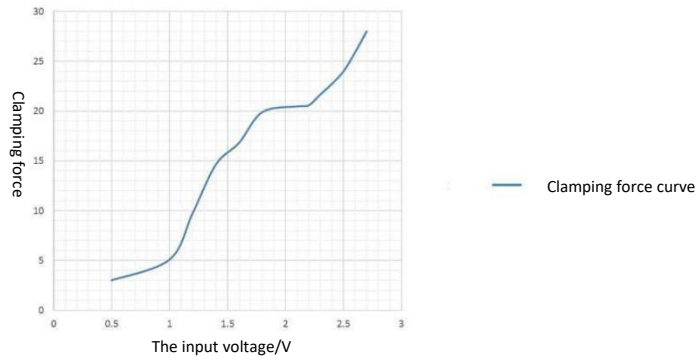

▲Precautions

The wires that must be connected include , +24V , GND , control signal (control direction, gripping or loosening).

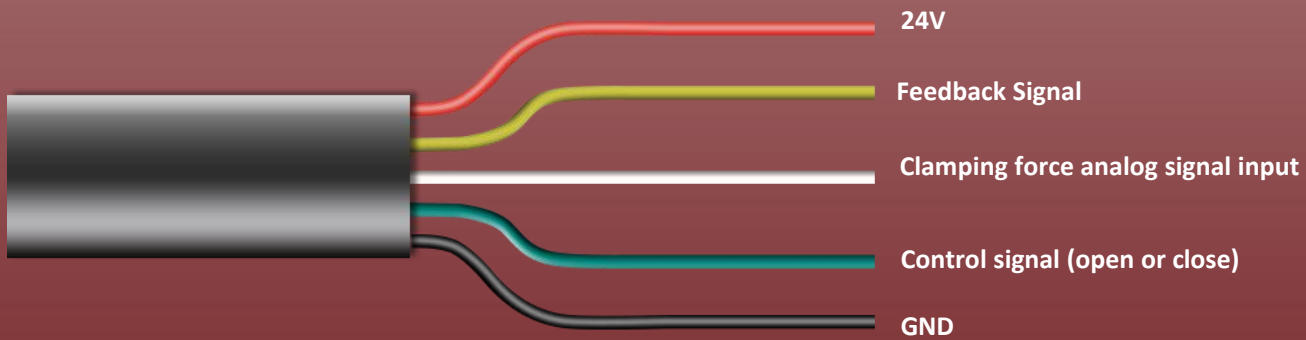

Z-EFG-12 Detailed Parameter Table



Items	Z-EFG-12
Total Travel (Effective)	12 mm
Gripping force	30 N
Maximum gripping weight	≤500 g
Repeated positioning	/
Full travel movement time	0.4S/ Opening and closing cycle
Oil supply for moving parts	Every six months or one million moves/time
Operating temperature	5~55 °C
Operating humidity range	RH35-80(No frost)
Mode of movemen	Two-finger translation
Travel adjustable	Not adjustable
Gripping force adjustable	Not adjustable
Body weight	0.342 kg
Size specification	44*28*105mm
Controller placement	Built - in
power	5W
Motor type	DC brushless
Peak current	≤1A
Rated voltage	24 V
Standby current	≤0.02A

Z-EFG-12 Installation diagram

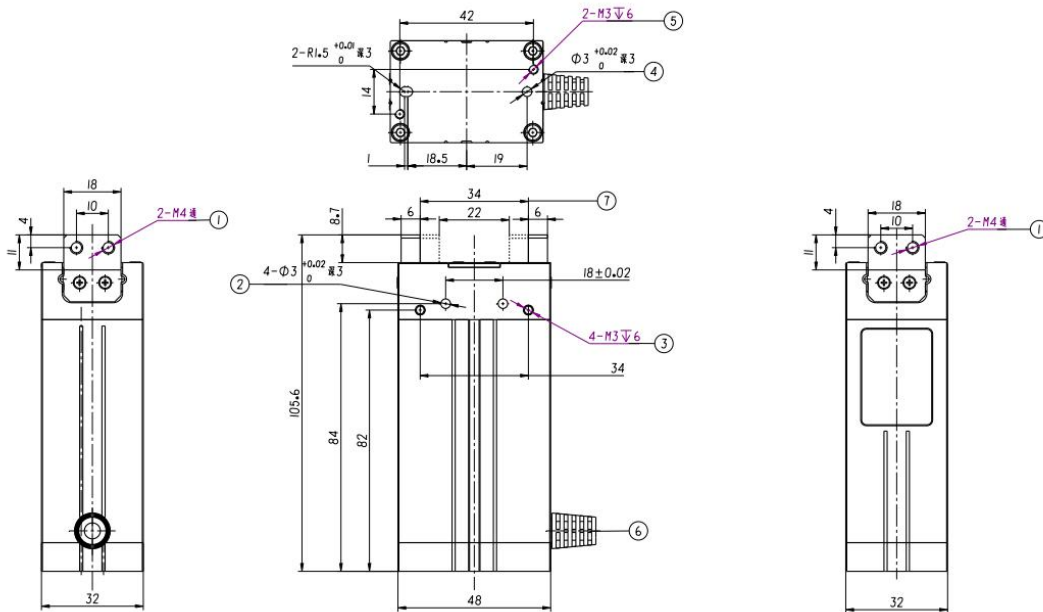

1. Gripper installation position (threaded hole)
2. Front mounting position (pin hole)
3. Front mounting position (threaded hole)
4. Bottom mounting position (pin hole)
5. Bottom mounting position (threaded hole)
6. Line outlet position of control line

Z-EFG-12 Wiring diagram

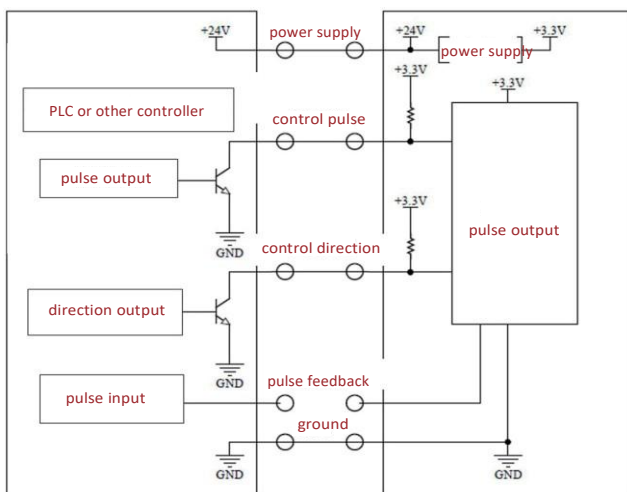

Z-EFG-12 NPN

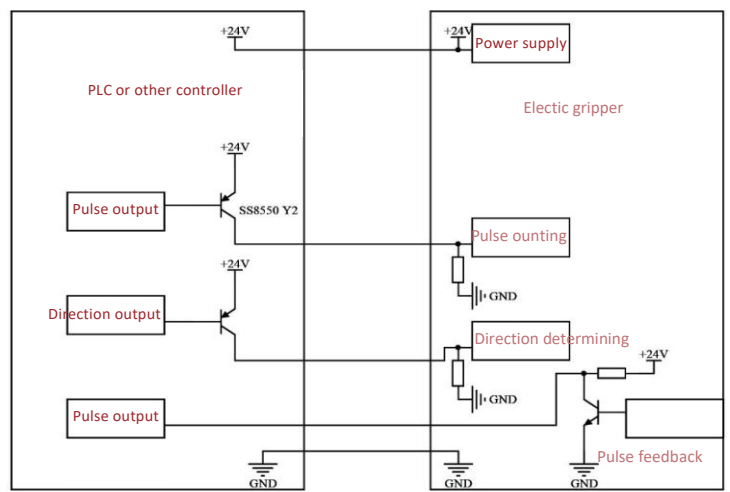

Z-EFG-12 PNP

■ ■ Z-EFG-12 Line sequence description (NK)

linetype	Function	Description	Remarks
Red line	24V	Power supply	Must be connected
Black line	GND	Power supply	Must be connected
Green line	Control signal (open)	If the logic level of the controller is 24V, it can be directly connected to the I/O port	Must be connected
		the optocoupler is connected in series to pull up the 2.2K resistor to 24V inside	
		If the output is NPN type IO, directly connect IO	
		If the controller output is PNP, select PNP gripper	
White line	Control signal (close)	same as above	Must be connected
Yellow line	Signal output	May not connect, only read signal, display LED status Output open circuit is open at the end of the movement, and 0V or 24V can be selected at the time of movement.	Select connection

■ ■ Z-EFG-12 Line sequence description (PK)

linetype	Function	Description	Remarks
Red line	24V	Power supply	Must be connected
Black line	GND	Power supply	Must be connected
Green line	Control signal (open)	If the logic level of the controller is 24V, it can be directly connected to the I/O port	Must be connected
		2.2k resistance in series with optocoupler	
		If the output is PNP type, directly connect to the gripper	
		If the controller output is NPN, select NPN gripper	
White line	Control signal (close)	same as above	Must be connected
Yellow line	Signal output	May not connect, only read signal, display LED status Output open circuit is open at the end of the movement, and 0V or 24V can be selected at the time of movement.	Select connection

Electric gripper Z-EFG-12 electrical parameters

Precautions

The wires that must be connected include, +24V, GND, and control signal (control opening)

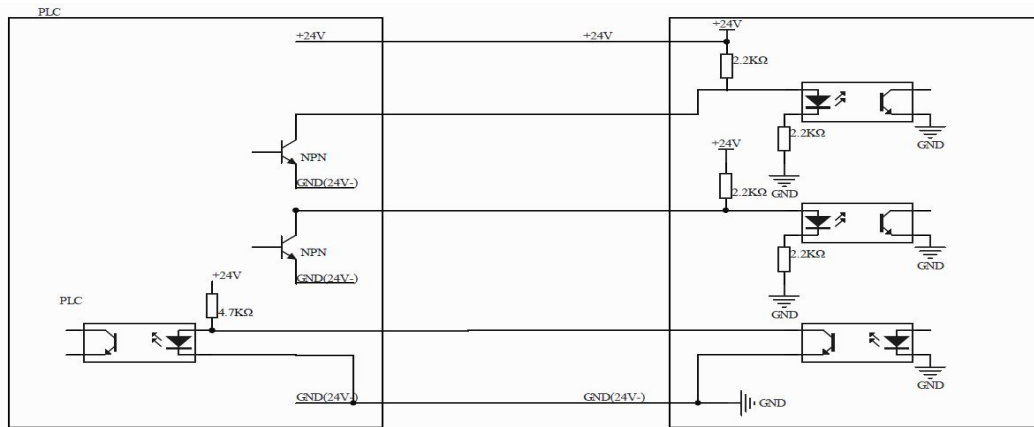

Wiring diagram

Electrical parameters

Rated voltage

24±2V Electric

current 0.2A

Peak current 1A

When both the control gripping and the control opening are effective or ineffective, the gripper has no action and no holding force

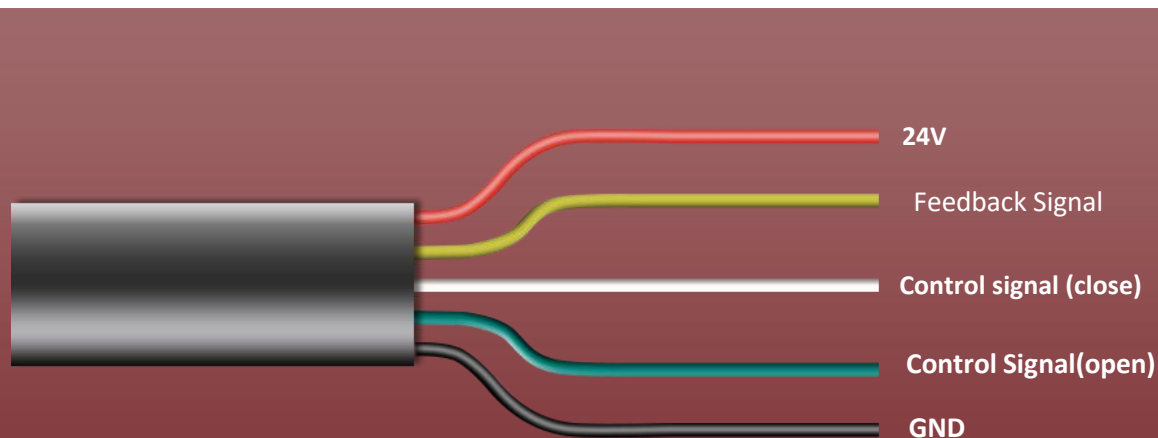

■ ■ ■ Z-EFG-20 Detailed Parameter Table



Items	Z-EFG-20
Total Travel (Effective)	20 mm
Gripping force	80 N
Maximum gripping weight	≤ 800 g
Repeated positioning	±0.02 mm
Motion components	Cross roller guide rail + rack and pinion
Oil supply for moving parts	Every six months or one million moves/time
Shock/shock resistance	98 m/s ²
Operating temperature	5~55°C
Operating humidity range	RH35-80(No frost)
Mode of movemen	Two-finger translation
Travel adjustable	adjustable
Gripping force adjustable	adjustable*
Body weight	0.458 kg
Size specification	44*30*120 mm
Controller placement	Built - in
power	5W
Motor type	DC brushless
The motor diameter	28 mm
Rated voltage	24 V
Standby current	≤ 0.02A

Z-EFG-20 Installation diagram

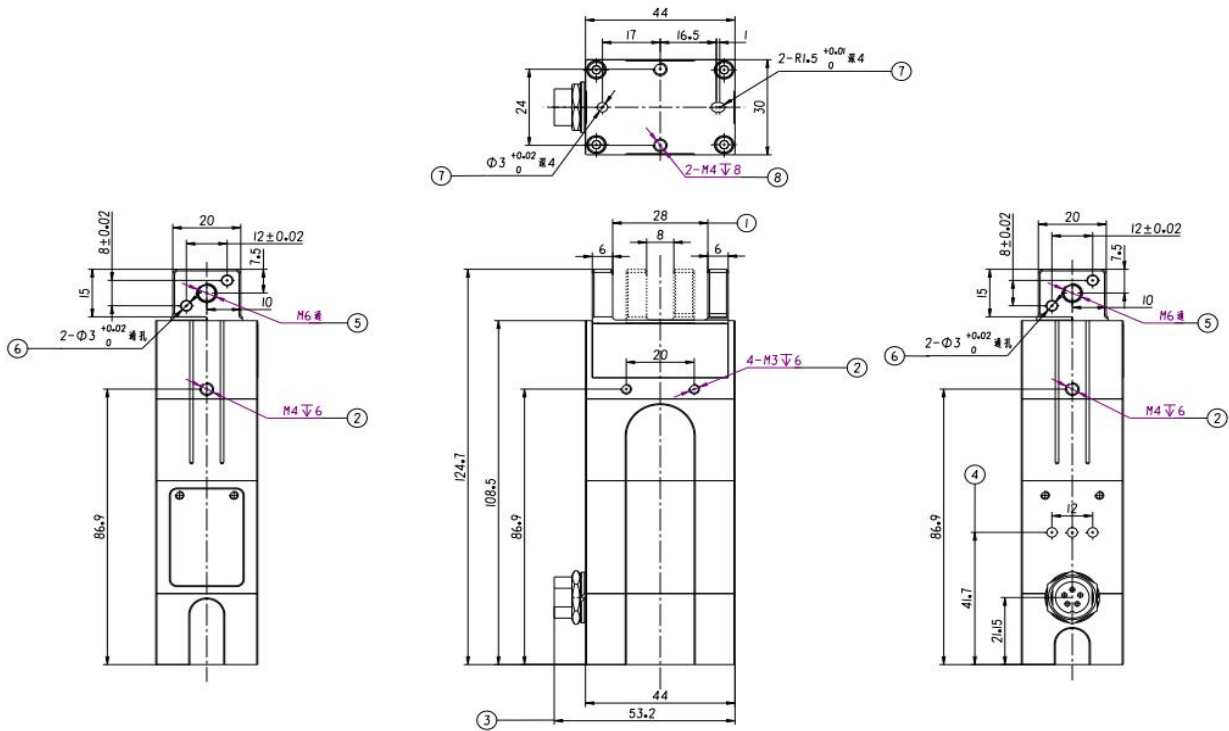

- 1.clamp mounting position (threaded hole)
- 2.Front mounting position (pin hole)
- 3.Front mounting position (threaded hole)
- 4.Bottom mounting position (pin hole)
- 5.Bottom mounting position (threaded hole)
- 6.Coontrol line outlet

Z-EFG-20 Wiring diagram

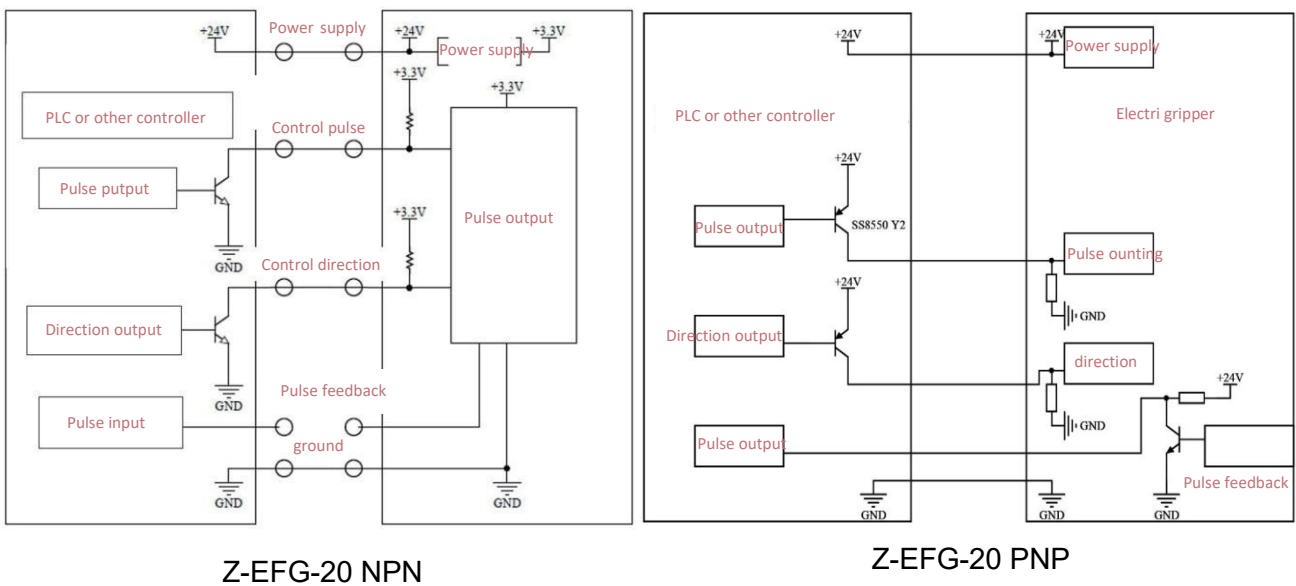

Z-EFG-20 Line sequence description (NM)

Pin	Function	Application method	Remarks
1	Control signal (open or close)	<p>If the logic level of the controller is 3.3V or 5V, connect the I/O port directly</p> <ul style="list-style-type: none"> ● Input with 0V-0.7V (low level), and pulse signal at the same time, the electric gripper open ● Input with 2.7V-5V (high level), and pulse signal at the same time, the electric gripper close <p>If the logic level of the controller is higher than 5V, Open Drain output can be used</p> <ul style="list-style-type: none"> ● When input with Open Drain output (invalid), and input with pulse signal at the same time, the electric gripper close ● When input with 0V-0.7V (valid), and input with pulse signal at the same time, the electric gripper open <p>If the logic level of the controller is higher than 5V and the second method cannot be used, a series resistance can be used, and when the control voltage is 24V, the series resistance is 8.2k</p> <ul style="list-style-type: none"> ● When the input is higher than 2.7V (high level), the electric gripper close ● When input with 0-VLow* (low level), the electric gripper open 	Must be connected
2	+24V	Power supply	Must be connected
3	Input pulse	<ul style="list-style-type: none"> ● Connection method and definition of high and low level are the same as pin #1 (control signal) ● Input 0~200 pulses to control the gripper moving for 0-20mm, with each pulse move for 0.1 mm ● The maximum number of input pulse is 200, 10mm each to the left and right side, with a maximum frequency of 5KHz, the high and low level effective time is not less than 200us, 1KHz corresponds to the max speed, the gripper exceeds the speed of 1KHz even the frequency is more than 5KHz 	Must be connected
4	Feedback pulse	<ul style="list-style-type: none"> ● Read-only output, not necessary to connect <p>The pulse is 0V, 3.3V pulse feedback, and the effective level time is 100us, which is related to the distance of the gripper opening or closing, one pulse occurred every 0.1mm inward/outward</p>	Optional
5	GND	Power supply	Must be connected

* Explanation

$$V_{Low} \leq 0.7 - 2.6 * R_x / 50K;$$

After power is applied, the front gripper will open to the maximum position (initialization).

Electric Gripper Z-EFG-20 Schematic diagram of aviation plug port

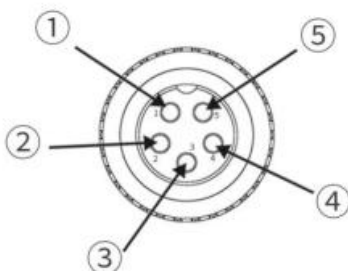

- ① Control Signal
- ② +24V
- ③ Input pulse
- ④ Feedback pulse
- ⑤ GND

Z-EFG-20 Line sequence description (NK)

Pin	Function	Application method	Remarks
1	Control Signal 1 (open or close)	<p>If the logic level of the controller is 3.3V or 5V, connect the I/O port directly</p> <ul style="list-style-type: none"> ● Input with 0V-0.7V (low level), and pulse signal at the same time, the electric gripper open ● Input with 2.7V-5V (high level), and pulse signal at the same time, the electric gripper close <p>If the logic level of the controller is higher than 5V, Open Drain output can be used</p> <ul style="list-style-type: none"> ● When input with Open Drain output (invalid), and input with pulse signal at the same time, the electric gripper close ● When input with 0V-0.7V (valid), and input with pulse signal at the same time, the electric gripper open <p>If the logic level of the controller is higher than 5V and the second method cannot be used, a series resistance can be used, and when the control voltage is 24V, the series resistance is 8.2k</p> <ul style="list-style-type: none"> ● When the input is higher than 2.7V (high level), the electric gripper close ● When input with 0-VLow* (low level), the electric gripper open 	Must be connected
2	+24V	Power supply	Must be connected
3	Control Signal 2 (Open or Close)	Same as Pin #1	Must be connected
4	Feedback Signal	<ul style="list-style-type: none"> ● Read-only output, not necessary to connect ,use to drive LED ● Output with 3.3V when the gripper is moving ,0V after the moving 	Optional
5	GND	Power supply	Must be connected

* Explanation

$$V_{Low} \leq 0.7 - 2.6 * R_x / 50K;$$

After power is supplied, the gripper will open to the maximum position (initialization).

Electric Gripper Z-EFG-20 Schematic diagram of aviation plug port

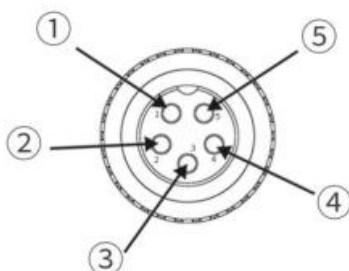

- ① Control Signal 1
- ② +24V
- ③ Control Signal 2
- ④ Feedback Signal
- ⑤ GND

■ ■ Z-EFG-20 Line sequence description (PM)

Pin	Function	Application method	Remarks
1	Control signal (open or close)	Output type of the PLC is 24V、PNP mode, directly connected to the I/O port When pin #1 and #4 are high level or low level at the same time, the gripper has no action. #1 is high and #4 is low , gripper close #1 is low and #4 is high , gripper open If the logic level of the controller is 24V ● Input within 19V~24V (high level) ● Input within 0V~12V(low level) ● Input Current < 5mA	Must be connected
2	+24V	Power supply	Must be connected
3	Feedback pulse	<ul style="list-style-type: none"> ● Read-only output, not necessary to connect ● Output with 0V(Low level) ● Output with 24V(High level) ● the effective level time of the pulse is 100us, which is related to the distance of the gripper opening or closing. One pulse occurred every 0.1mm movement inward/outward ● Type of the output is NPN ,with a pull-up resistance to 24V inside 	optional
4	Input pulse	<ul style="list-style-type: none"> ● Connection method and definition of high and low level are the same as pin # 1 (control signal) ● Input 0~200 pulses to control the gripper moving for 0-20mm, with each pulse move for 0.1 mm ● The maximum number of input pulse is 200, 10mm each to the left and right side , with a maximum frequency of 5KHz, the high and low level effective time should be not less than 200us, 1KHz corresponds to the max speed, the gripper exceeds the speed of 1KHz ,even the frequency is more than 5KHz 	Must be connected
5	GND	Power supply	Must be connected

* Explanation

After power is applied, the front gripper will open to the maximum position (initialization)

Electric Gripper Z-EFG-20 Schematic diagram of aviation plug port

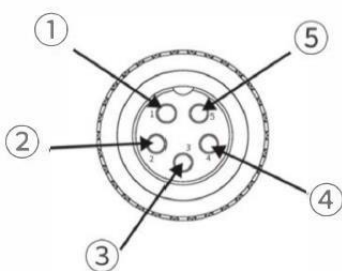

- ① Control Signal
- ② +24V
- ③ Feedback pulse
- ④ Input pulse
- ⑤ GND

Z-EFG-20 Line sequence description (PK)

Pin	Function	Application method	Remarks
1	Control signal 1 (Open or close)	Output type of the PLC is 24V、PNP mode, directly connected to the I/O port When pin #1 and #4 are high level or low level at the same time, the gripper has no action. #1 is high and # 4 is low , gripper close #1 is low and # 4 is high , gripper open If the logic level of the controller is 24V ● Input within 19V~24V (high level) ● Input within 0V~12V(low level) ● Input Current < 5mA	Must be connected
2	+24V	Power supply	Must be connected
3	Feedback Signal	● Read-only output, not necessary to connect ,use to drive LED ● Output with 24V when the gripper is moving(with a 4.7k pull-up resistance to 24V inside) ,0V after the moving	optional
4	Control Signal 2 (Open or close)	Same as Pin #1	Must be connected
5	GND	Power supply	Must be connected

* Explanation

After power is applied, the front gripper will open to the maximum position (initialization)

Electric Gripper Z-EFG-20 Schematic diagram of aviation plug port

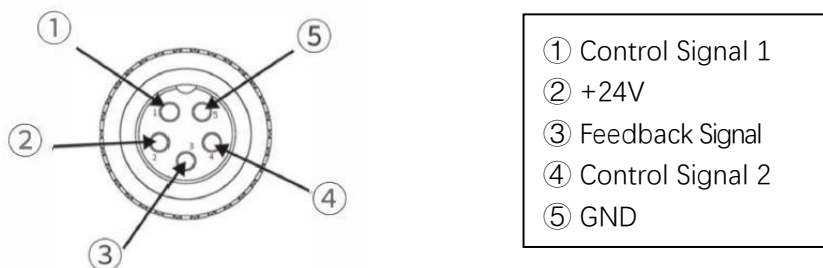

■ ■ Electric gripper Z-EFG-20 electrical parameters

- Rated voltage 24±10%
- Standby current is less than 0.02A
- Peak current 1.5 A

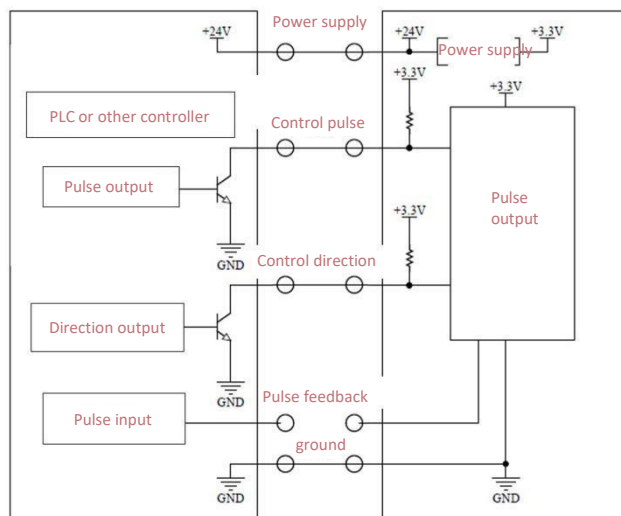

Wiring diagram



■ ■ ■ Z-EFG-F Detailed Parameter Table



Items	Z-EFG-F
Total Travel (Effective)	8 mm
Gripping force	5-30 N
Maximum gripping weight	≤300 g
Repeated positioning	/
Motion components	Cross roller guide rail + rack and pinion
Oil supply for moving parts	Every six months or one million moves/time
Shock/shock resistance	98 m/s ²
Operating temperature	5~55 °C
Operating humidity range	RH35-80(No frost)
Mode of movemen	Two-finger translation
Travel adjustable	Not adjustable
Gripping force adjustable	adjustable
Body weight	0.235 kg
Size specification	30*24*94 mm
Controller placement	Built - in
power	3.6 W
Motor type	DC brushless
The motor diameter	17 mm
Rated voltage	24 V
Standby current	≤0.02A

■ ■ Z-EFG-F Installation diagram

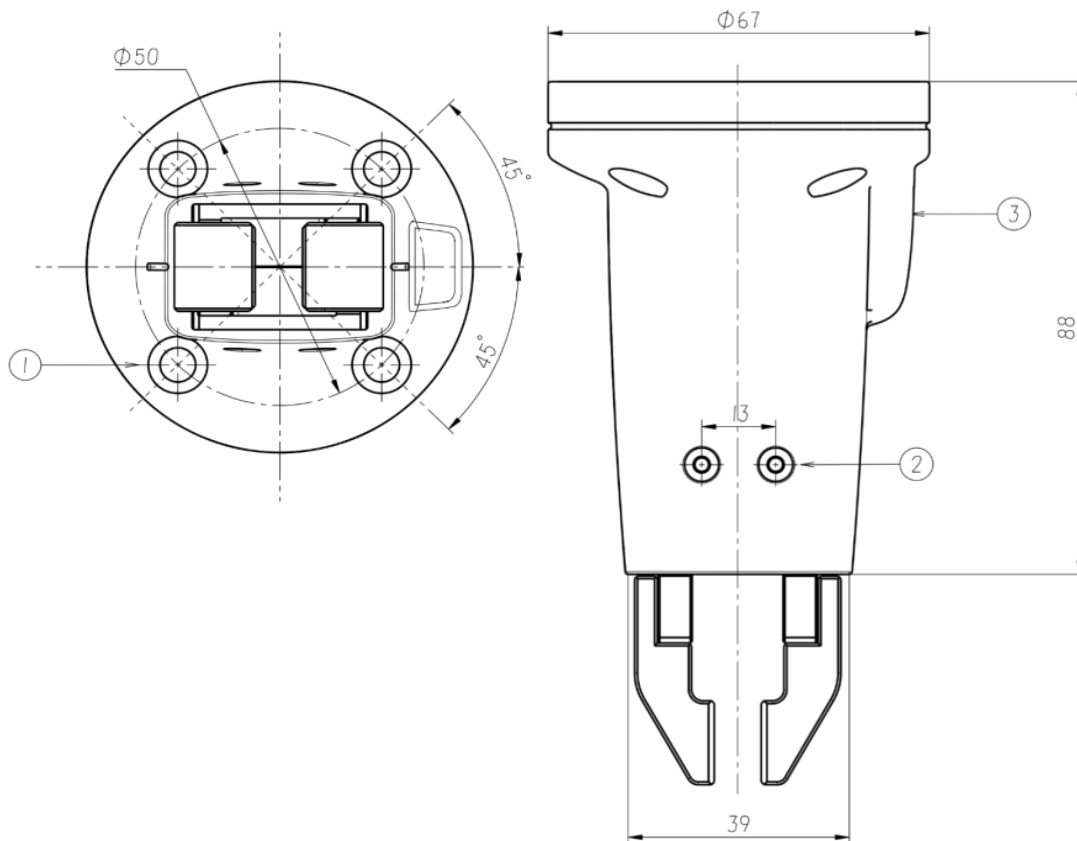

- ①: UR arm flange mounting position
- ②: Z-EFG-F electric gripper mounting hole
- ③: Control line outlet hole

■ ■ Z-EFG-F Line sequence description (NPN)

linetype	Function	Description	Remarks
Red line	24V	Power supply	Must be connected
Shielded wire	GND	Power supply	Must be connected
Green line	Control Signal (Control Clamp or Release)	<p>If the logic level of the controller is 3.3V or 5V, the I/O port can be directly connected.</p> <ul style="list-style-type: none"> ● When 0V-0.7V is input (low level), the electric gripper opens outward ● When 2.7V-3.3V is input (high level), the electric gripper clamps inward <p>If the logic level of the controller is higher than 5V, Open Drain output can be used</p> <ul style="list-style-type: none"> ● When Open Drain (high level) is output, the electric gripper is clamped inward ● When 0V-0.7V is input (low level), the electric gripper opens outward <p>If the logic level of the controller is higher than 5V and the second method cannot be used, a resistor $R_x \leq 8.2K$ can be connected in series</p> <ul style="list-style-type: none"> ● When 2.7V is input (high level), the electric gripper clamps inward ● When 0-V_{Low}* is input (low level), the electric gripper opens outward 	Must be connected
White line	gripping force analog signal input	<ul style="list-style-type: none"> ● May not connect* ● During connection, it is used to continuously adjust the clamping force. Input 0.5~2.7V, and output 0-30N corresponding to the clamping force. The higher the input value, the greater the clamping force 	Select connection
Black line	Signal output	<ul style="list-style-type: none"> ● May not connect, only read signal, display LED status ● Output 0V when moving and 3.3V when moving is over 	Select connection

* Explanation

1. When the white line is not connected, the gripping force is controlled by potentiometer. When the white line is connected, the gripping force is controlled by white line signal
2. The potentiometer is located above the connector on the side of the electric gripper
3. When leaving the factory, the potentiometer defaults to a vertical state. If the white line is not connected at this time, the gripping force is 20N, which is increased clockwise and decreased counterclockwise (vertical is 0, counterclockwise is negative, clockwise is positive)
4. 30N for +60°, 0N for -60°
6. Please do not rotate the potentiometer to the maximum or minimum position (62.7°). When the potentiometer is at the maximum or minimum position, the electric gripper will be in a protected state (stationary)
6. $V_{Low} \leq 0.7 - 2.6 * R_x / 50K$

■ ■ Electric gripper Z-EFG-F clamping force curve

Different s pass through white lines and output different gripping forces.

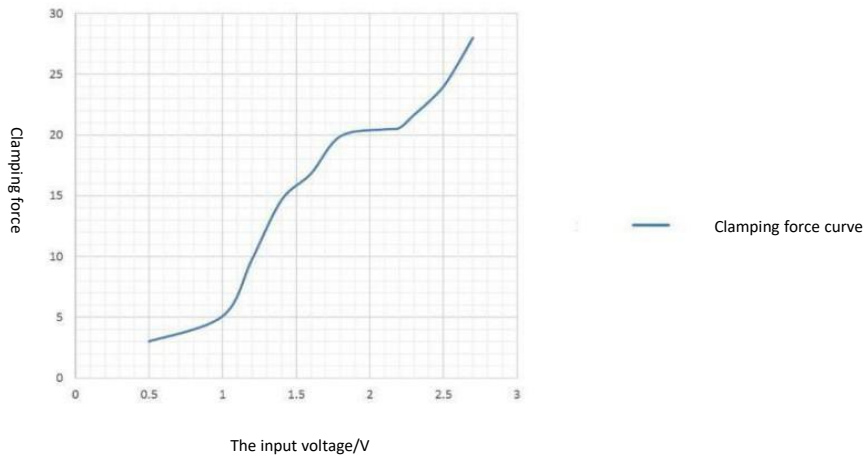

▲Matters needing attention

The wires that must be connected include, +24V, GND, control signal (control direction, gripping or loosening).

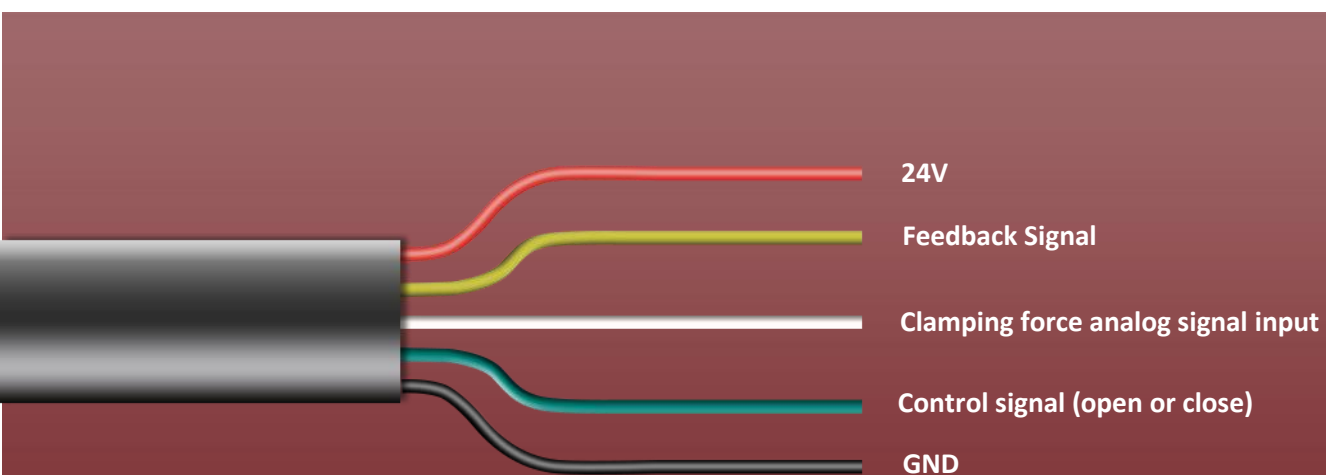

■ ■ ■ Z-EFG-L Detailed Parameter Table



Items	Z-EFG-L
Total Travel (Effective)	12 mm
Gripping force	30 N
Maximum gripping weight	≤ 500 g
Repeated positioning	/
Full stroke movement time	0.4S/ Opening and closing cycle
Oil supply for moving parts	Every six months or one million moves/time
Operating temperature	5~55 °C
Operating humidity range	RH35-80(No frost)
Mode of movemen	Two-finger translation
Travel adjustable	Not adjustable
Gripping force adjustable	Not adjustable
Body weight	0.342 kg
Size specification	44*28*105mm
Controller placement	Built - in
power	5W
Motor type	DC brushless
peak current	≤ 1A
Rated voltage	24 V
Standby current	≤ 0.02A

■ ■ Z-EFG-L Installation diagram

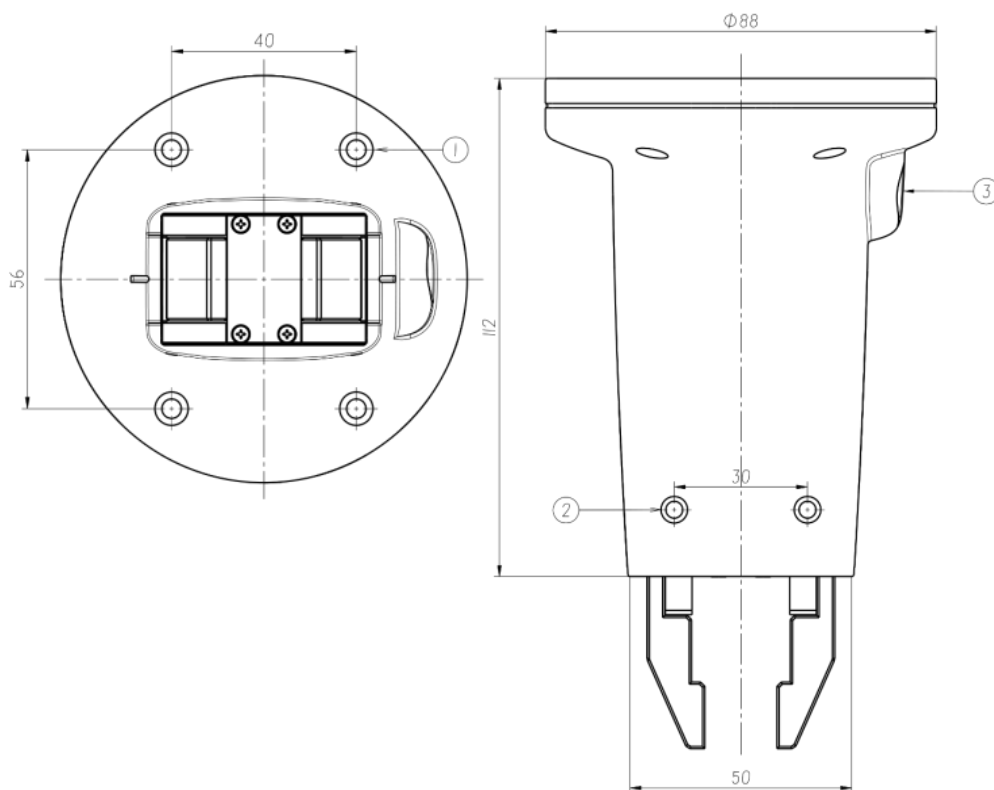

- ①: Z-arm flange mounting bit
- ②: Z-EFG-L electric gripper mounting hole
- ③: Control line outlet hole

■ ■ Z-EFG-L Line sequence description (NPN)

linetype	Function	Description	Remarks
Red line	24V	Power supply	Must be connected
Shielded wire	GND	Power supply	Must be connected
Green line	Control Signal (Control Clamp or Release)	If the logic level of the controller is 24V, it can be directly connected to the I/O port the optocoupler is connected in series to pull up the 2.2K resistor to 24V inside	Must be connected
		If the output is NPN IO, the IO can be directly connected	
		If the controller output is PNP, select PNP gripper	
White line	Control signal (control opening)	same as above	Must be connected
Black line	Signal output	<ul style="list-style-type: none"> ● May not connect, only read signal, display LEDstatus ● Output open circuit when moving is over, output 0v when moving 	Select connection

■ ■ Electric gripper Z-EFG-L electrical parameters

Precautions

The wires that must be connected include, +24V, GND, and control signal (control opening)

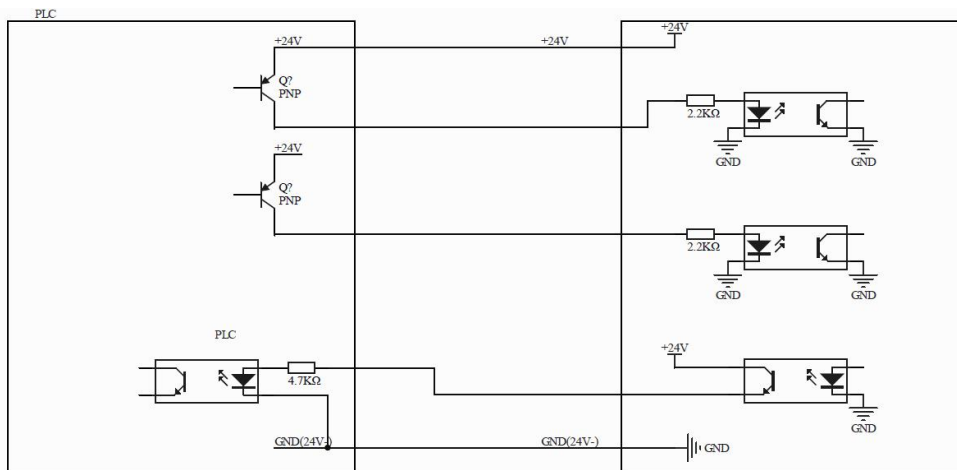

Wiring diagram

Electrical parameters

- Rated voltage 24±2V
- Electric current 0.2A
- Peak current 1A

When both control persistence and control opening are effective or ineffective, the gripper has no action and no holding force

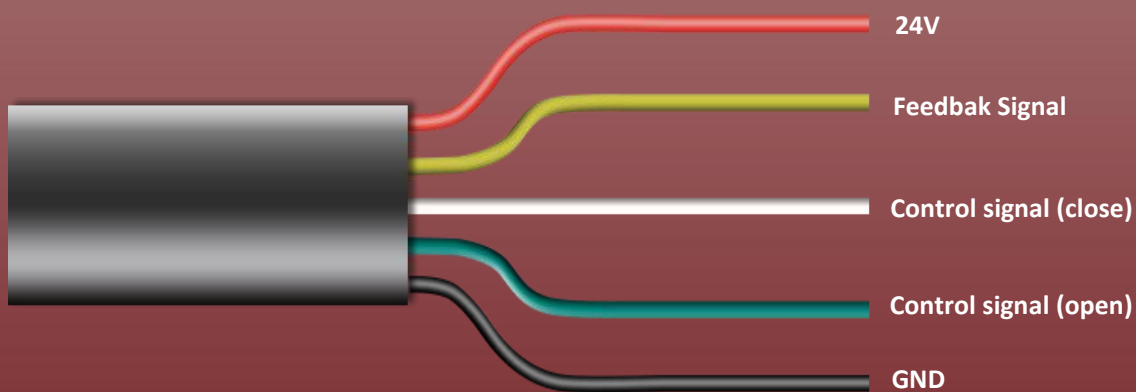

■ ■ ■ Z-EFG-R Detailed Parameter Table



Items	Z-EFG-R
Total Travel (Effective)	20 mm
Gripping force	80 N
Maximum gripping weight	≤800 g
Repeated positioning	±0.02 mm
Moving element	Cross roller guide+ pinion and rack
Oil supply for moving parts	Every six months or one million moves/time
Shock/vibration resistant	98 m/s ²
Operating temperature	5~55 °C
Operating humidity range	RH35-80(No frost)
Mode of movemen	Two-finger translation
Travel adjustable	adjustable
Gripping force adjustable	Not adjustable
Body weight	0.458 kg
Size specification	44*30*120 mm
Controller placement	Built - in
power	5W
Motor type	DC brushless
Motor diameter	28 mm
Rated voltage	24 V
Standby current	≤0.02A

■ ■ Z-EFG-R Installation diagram

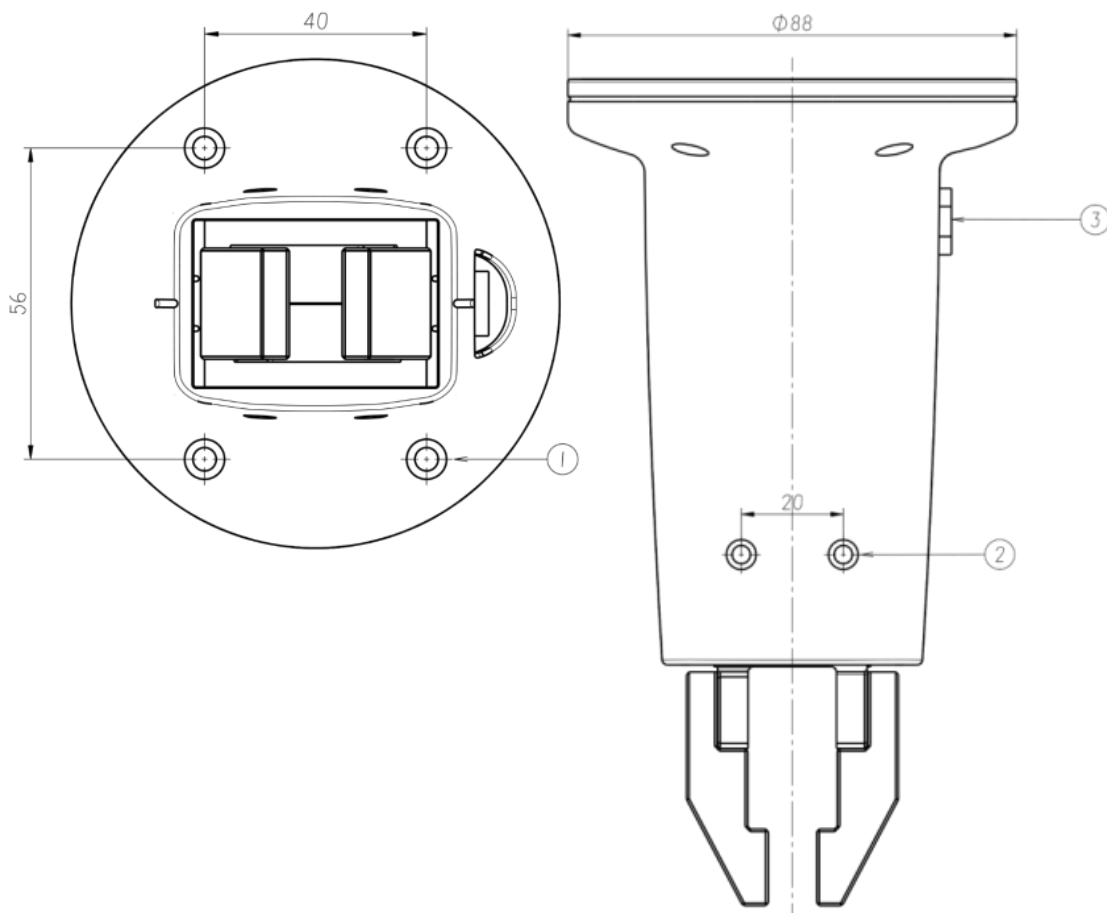

- ①: Z-Arm flange mounting bit
- ②: Z-EFG-R electric gripper mounting hole
- ③: Air plug outlet hole

Z-EFG-R Line sequence description (NK)

Port	Function	Application method	Remarks
1	Control signal (Control open or close)	<p>If the logic level of the controller is 3.3V or 5V, connect the I/O port directly</p> <ul style="list-style-type: none"> ● Input with 0V-0.7V (low level), and pulse signal at the same time, the electric gripper open ● Input with 2.7V-5V (high level), and pulse signal at the same time, the electric gripper close <p>If the logic level of the controller is higher than 5V, Open Drain output can be used</p> <ul style="list-style-type: none"> ● When input with Open Drain output (invalid), and input with pulse signal at the same time, the electric gripper close ● When input with 0V-0.7V (valid), and input with pulse signal at the same time, the electric gripper open <p>If the logic level of the controller is higher than 5V and the second method cannot be used, a series resistance can be used, and when the control voltage is 24V, the series resistance is 8.2k</p> <ul style="list-style-type: none"> ● When the input is higher than 2.7V (high level), the electric gripper close ● When input with 0-VLow* (low level), the electric gripper open 	Must be connectecd
2	+24V	Power supply	Must be connectecd
3	Control signal (Control open or close)	Same as pin #1	Must be connectecd
4	Feedback Signal	<ul style="list-style-type: none"> ● only read output, may not connect ● Output 0V is low level ● Output 3.3V is high level 	Select connection
5	GND	Power supply	Must be connectecd

* Explanation

1. $V_{Low} \leq 0.7 - 2.6 * R_x / 50K$;

3. After power is applied, the front gripper will open to the maximum position (initialization).

Physical drawing of Electric Gripper Z-EFG-R aviation plug port

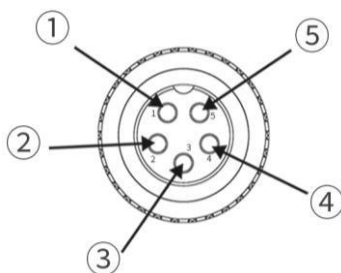

- ① Control signal 1
- ② +24V
- ③ Control signal 2
- ④ Feedback Signal
- ⑤ GND

■ ■ Electrical parameters of electric gripper Z-EFG-R

- Rated voltage $24 \pm 2V$
- Electric current 0.4A

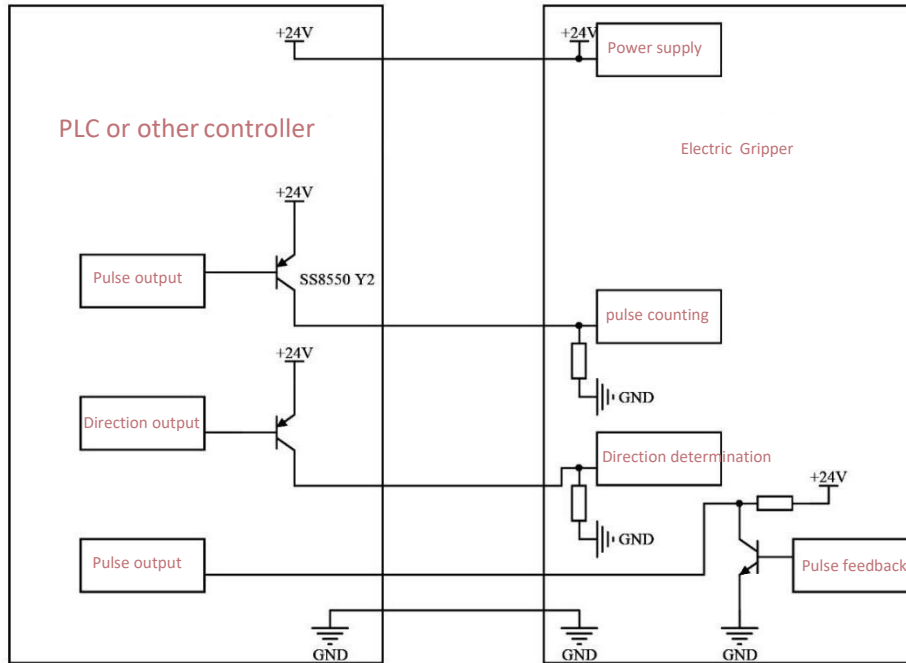

Wiring diagram



Control board instructions

The design of the control board allows the user to conveniently use the RS485 Modbus bus structure to control the 20mm NPN gripper.

Address optional: Modbus slave address is selected through 4-bit encoder. Currently, up to 16 gripper can be mounted on the same bus.

RS485 communication configuration: control board baud rate 9600bps, no parity bit, 2-bit STOP bit;

Modbus mode: RTU;

Modbus address: $0xA0 + \text{dip switch}$, e.g. dip switch all dial ON, address $0xA0 + 0 = 160$

Data address 41000: set position registers 0~200, read and write are effective, if the sending value is less than 0, the register value is 0.

If the sending value is > 200 , the register value is 200;

Data address 41001: Reserved register, read and write valid; It has no effect on the register write value.

Data address 41002: current feedback position register 0~200, read valid, write without any influence, feedback value is current position 0 of gripper, and "0" when it is opened to the maximum position;

Hardware wiring diagram

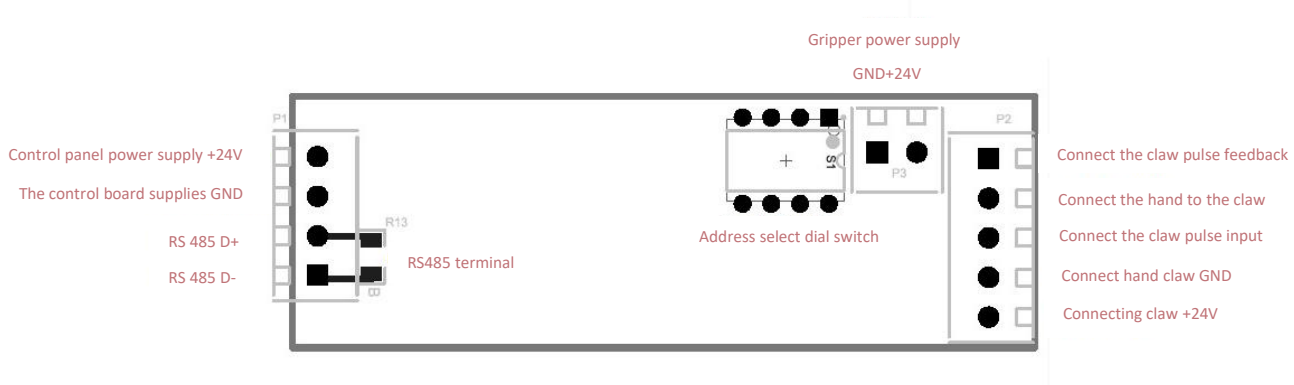

control board power supply, connection gripper pulse feedback, connection gripper direction, connection gripper pulse input, connection gripper, gripper power supply, address selection dip switch, 485 terminal resistance

Terminal resistance is recommended to be removed when the equipment is not RS485 terminal. Using Modbus gateway to convert Ethernet Modbus to RTU RS485 Modbus:

①、Configure Modbus gateway

According to the requirements of the control board, the configuration is: board baud rate 9600bps, no parity bit, 2-bit STOP bit, RS485, RTU mode;

②、Configure Modbus server IP address and port;

③、Operate the register by sending Modbus Ethernet communication protocol to Modbus gateway through network cable, the 20mm gripper can be controlled and the feedback position can be observed.

■ ■ Instructions for use of Electric Gripper Isolation Board wiring

■ Electric Gripper Z-EFG-8

Electric gripper Z-EFG-8 isolation only supports isolation when analog control is not used.

There are two wiring methods for the isolation board, one is single control line, plus one feedback line, the other is double control lines.

1.single control line, plus one feedback line, connection method is as follows: Control direction, feedback signal
Controller side, gripper side

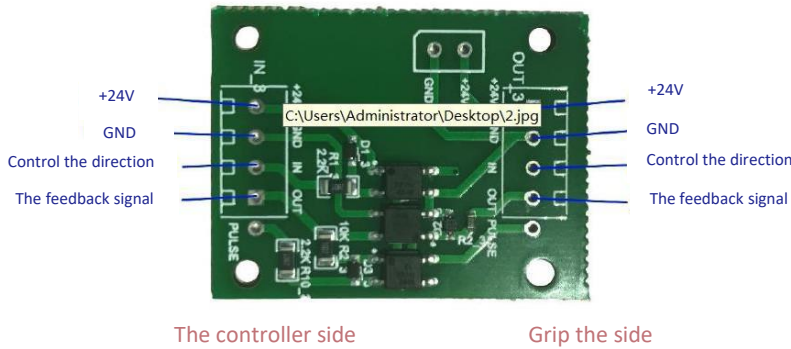

2.double control lines, connection method is as follows:
Control direction, control line
Controller side, gripper side

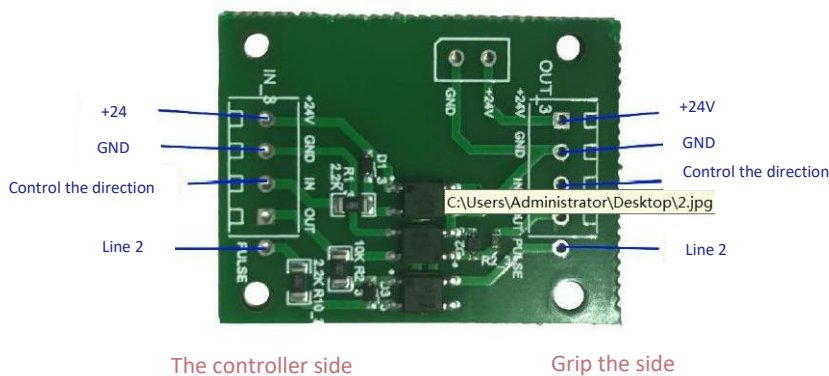

■ Electric Gripper Z-EFG-20

The wiring method of the electric gripper Z-EFG-20 isolation board is as follows:

Control direction, feedback signal pulse signal

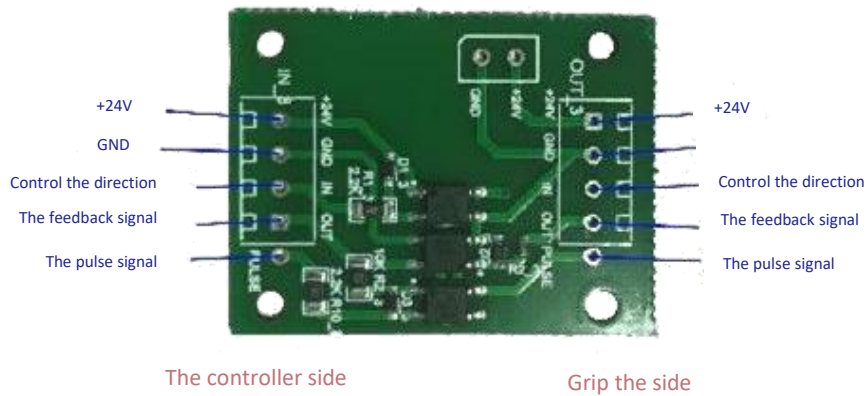

★ Isolated or non-isolated use

Both electric gripper Z-EFG-8 and Z-EFG-20 models can be used in isolation or non-isolation. When not isolated:
 Back 2 jumper short circuit: no additional 24V power supply is required

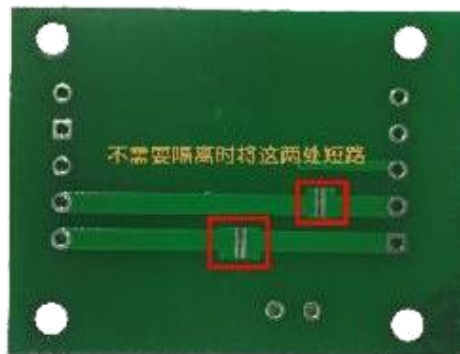

Isolated power supply :

Disconnect jumper wire to supply power through socket side: when in use, the isolation board should be as close to the gripper as possible to reduce interference to the gripper as possible to reduce interference.

Isolated power supply

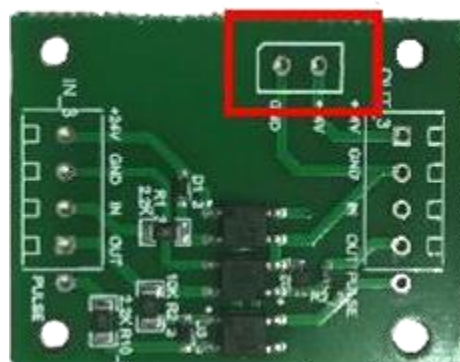

■ ■ ■ Z-EFG-100 Detailed Parameter Table

Items	Z-EFG-100
Total Travel (Effective Travel)	90mm
Gripping force	35-60N
Maximum gripping weight	500g
Repeated positioning accuracy	±0.02mm
Closing or Opening time	1s
Operating temperature range	5-55°C
Adjustable stroke	Adjustable
Adjustable clamping force range	Adjustable
Weight	925g
Dimensions	204*138.5*45(Open)222*79*45 (Close)
Placement mode of controller	Built-in controller
Power	30W
Rated voltage	24V

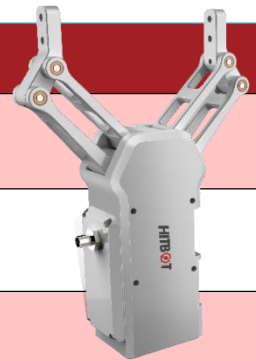

■ ■ Z-EFG-100 Installation diagram

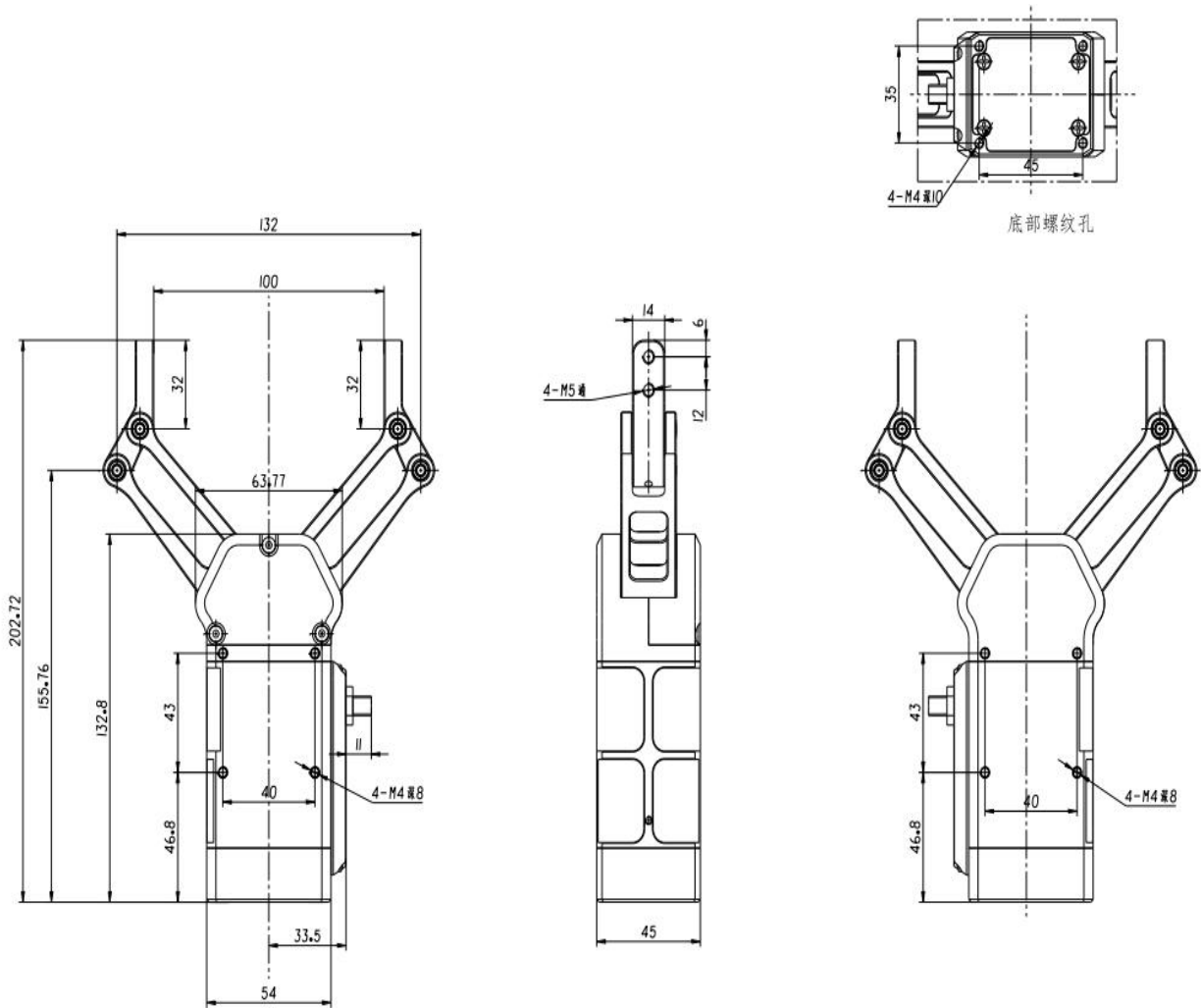

- ① 4-core av1at1on plug
- ② Clamp mounting position
- ③ Side mounting position
- ④ Bottom mounting position
- ⑤ Dimensions(Open)
- ⑥ Dimensions(Close)

■ ■ Connection mode

Z-EFG-100 adopts 4-core M8 aviation plug-in external connection. The matching connection can choose 180°outlet mode and 90°outlet mode. When 90°outlet mode is selected, the outlet direction is the tail end of gripper (no gripper finger end).

The line color of the matching cable is defined as follows:

Brown	24V+
Blue	0V(24V-, GND)
White	TIA/EIA-485-
Black	TIA/EIA-485+

Notice:

1. Please make sure that the positive and negative poles of the power cord are correct when wiring, 485 communication line and power cord are correct, and burning due to wrong wiring is not within the scope of normal warranty.
2. EIA485 and 24V gripper are not isolated internally. If isolation is needed, customers need to use other equipment for isolation.

■ ■ Communication protocol

The communication protocol is carried out in half-duplex mode, i.e. the upper computer /PLC send the control command to the lower computer, and after a period of time (configurable), the lower computer returns the command to the upper computer.

Communication supports bus-type control, and different ID numbers and ID ranges of 0x00~0xFE can be configured for the gripper. 0xFF is a broadcast command, all jaws will respond, but no command will be returned.

The upper computer sends a read-write instruction to the gripper as follows:

Data head fixed length 3byte			ID 1byte	Read/Write	Start address 1byte	Data len 1byte	Data(len byte1)(write)	CRC8 1byte
0x48	0x49	0x74	0~0xFF	0x00 read/0x01write	(0x00~0xFF)	0x00~0xFF	0x00~0xFF	CRC-8

Kixed length ot data header 3 byte			ID 1byte	Read/Write	Start address 1byte	Data len 1byte	Data(len byte1)(write)	CRC8 1byte
0x48	0x49	0x74	0~0xFF	0x00 read/0x01write	(0x00~0xFF)	0x00~0xFF	0x00~0xFF	CRC-8

The structure for the gripper to return a write command to the upper computer is as follows:

Data head fixed length 3byte			ID 1byte	Status	CRC8 1byte
0x46	0x4A	0x48	0~0xFF	/	CRC-8 1byte

Kixed length of data header 3byte			ID 1byte	Start address 1byte	CRC8 1byte
0x46	0x4A	0x48	0~0xFF	/	CRC-8 1byte

Where status is the status of register 0x6C, indicating the current err status.

The structure of the gripper returning the read command to the upper computer is as follows:

数据头 固定长度3byte			ID 1byte	Start address 1byte	Data len 1byte	Data(len byte)	CRC8 1byte
0x46	0x4A	0x48	0~0xFF	(0x00~0xFF)	(0x00~0xFF)	0x00~0xFF	CRC-8

CRC-8 is the data check for the whole paragraph, starting from the data header, the upper computer starts from 0x48, and the gripper return instruction starts from 0x46.

CRC-8 check polynomial is x^8+x^2+x+1 , and there is no inverted XOR reference code:

```
#define CRC8_INIT 0
#define XOROUT 0
/**
 * brief   CRC8_Calc
 * param   p_data* not change when run this fun
 *         len <255
 * retval  CRC-8
 */
U8 CRC8_Calc(U8 *p_data, U8 len)
{
    U16 window;
    U8 i,j, *crc8_h, *crc8_l;
    crc8_h = (U8*)&window+1;
    crc8_l = (U8*)&window;
    *crc8_h = CRC8_INIT;
    for(j=0; j<=len; j++)
    {
        if(j < len)
        {
            *crc8_l = *p_data;
        }
        p_data++;
        for(i=0; i<8 ;i++)
        {
            if((*crc8_h & 0x80) != 0)
            {
                //xor
                window <<= 1;
                *crc8_h ^= CRC8_POLY;
            }
            else
            {
                window <<= 1;
            }
        }
    }
    return ((*crc8_h)^XOROUT);
}
```

Register address and description

Address 0x00~ address 0x55 are EEPROM backup addresses, which are read into RAM by EEPROM at each power-up. modification of these values will not affect EEPROM. If the modified values are written into EEPROM by instruction, the modified values will be read from EEPROM at the next power-up

address	Name	R/W	Reset value	Description
0x00	ID	R/W	0x01	0x00~0xEF,0*FF is the broadcast address
0x01	baudrate	R/W	BauRate_1000000	0: BaudRate_1000000 1: BaudRate_500000 2: BaudRate_115200 3: BaudRate_57600 4: BaudRate_38400 5: BaudRate_9600 Other: BaudRate_9600
0x02	Version_L	R	0	
0x03	Version_H	R	0	
0x04	Time delay_L	R/W	0x00	485communication return delay"0"returns at maximum speed us
0x05	Time delay_H	R/W		
0x06	Mode 1 position_L	R/W	0x1F4 (500)	(100~1000) Set position
0x07	Mode 1 position_H	R/W		
0x08	Mode 1 speed	R/W	0xFF	(0~0xFF) The slowest to the fastest
0x09	Mode 1 torque	R/W	0xFF	(0~0xFF) Minimum to Maximum Force
0x0A	Mode 1 feedback_position_min_L	R/W	0x1C2	(100~1000) When stopped, small value for Range detection
0x0B	Mode 1 feedback_position_min_H	R/W		
0x0C	Mode 1 feedback_position_max_L	R/W	0x266 (550)	(100~1000) When stopped, large value for Range detection
0x0D	Mode 1 feedback_position_max_H	R/W		
0x0E	Mode2 position_L	R/W	Let's repeat mode1 Repeat below model	
0x0F	Mode2 position_H	R/W		
0x10	Mode2 speed	R/W	0x10	
0x11	Mode2 torque	R/W	0x11	
0x12	Mode2 Feedback_position_min_L	R/W	0x12	
0x13	Mode2 Feedback_position_min_H	R/W	0x13	
0x14	Mode2 Feedback_position_max_L	R/W	0x14	
0x15	Mode2 Feedback_position_max_H	R/W	0x15	
0x16	Mode3 position_L	R/W	0x16	
0x17	Mode3 position_H	R/W	0x17	
0x18	Mode3 speed	R/W	0x18	
0x19	Mode3 torque	R/W	0x19	
0x1A	Mode3 feedback_position_min_L	R/W	0x1A	
0x1B	Mode3 feedback_positon_min_H	R/W	0x1B	

0×1C	Mode3 feedback_position_max_L	R/W		
0×1D	Mode3 feedback_position_max_H	R/W		
0×1E	Mode4 position_L	R/W		
0×1F	Mode4 position_H	R/W		
0×20	Mode4 speed	R/W		
0×21	Mode4 torque	R/W		
0×22	Mode4 feedback_position_min_L	R/W		
0×23	Mode4 feedback_position_min_H	R/W		
0×24	Mode4 feedback_position_max_L	R/W		
0×25	Mode4 feedback_position_max_H	R/W		
0×26	Mode5 position_L	R/W		
0×27	Mode5 position_H	R/W		
0×28	Mode5 speed	R/W		
0×29	Mode5 torque	R/W		
0×2A	Mode5 feedback_position_min_L	R/W		
0×2B	Mode5 feedback_position_min_H	R/W		
0×2C	Mode5 feedback_position_max_L	R/W		
0×2D	Mode5 feedback_position_max_H	R/W		
0×2E	Mode6 position_L	R/W		
0×2F	Mode6 position_H	R/W		
0×30	Mode6 speed	R/W		
0×31	Mode6 torque	R/W		
0×32	Mode6 feedback_position_min_L	R/W		
0×33	Mode6 feedback_position_min_H	R/W		
0×34	Mode6 feedback_position_max_L	R/W		
0×35	Mode6 feedback_position_max_H	R/W		
0×36	Mode7 position_L	R/W		
0×37	Mode7 position_H	R/W		
0×38	Mode7 speed	R/W		
0×39	Mode7 torque	R/W		
0×3A	Mode7 feedback_position_min_L	R/W		
0×3B	Mode7 feedback_position_min_H	R/W		
0×3C	Mode7 feedback_position_max_L	R/W		
0×3D	Mode7 feedback_position_max_H	R/W		
0×3E	Mode8 position_L	R/W		
0×3F	Mode8 position_H	R/W		
0×40	Mode8 speed	R/W		
0×41	Mode8 torque	R/W		
0×42	Mode8 feedback_position_min_L	R/W		
0×43	Mode8 feedback_position_min_H	R/W		
0×44	Mode8 feedback_position_max_L	R/W		

0×45	Mode8 feedback_position_max_H	R/W		
0×46	Mode9 position_L	R/W		
0×47	Mode9 position_H	R/W		
0×48	Mode9 speed	R/W		
0×49	Mode9 torque	R/W		
0×4A	Mode9 feedback_position_min_L	R/W		
0×4B	Mode9 feedback_position_min_H	R/W		
0×4C	Mode9 feedback_position_max_L	R/W		
0×4D	Mode9 feedback_position_max_H	R/W		
0×4E	Mode10 position_L	R/W		
0×4F	Mode10 position_H	R/W		
0×50	Mode10 speed	R/W		
0×51	Mode10 torque	R/W		
0×52	Mode10 feedback_position_min_L	R/W		
0×53	Mode10 feedback_position_min_H	R/W		
0×54	Mode10 feedback_position_max_L	R/W		
0×55	Mode10 feedback_position_max_H	R/W		
Address 0x60~ Address 0xA3 Run Register, stored in RAM Lost in Power Loss				
address	Name	R/W	instructions	note
0×60	Mode0 position_L	R/W		
0×61	Mode0 position_H	R/W		
0×62	Mode0 speed	R/W		
0×63	Mode0 torque	R/W		
0×64	Mode0 feedback_position_min_L	R/W		
0×65	Mode0 feedback_position_min_L	R/W		
0×66	Mode0 feedback_position_min_L	R/W		
0×67	Mode0 feedback_position_min_L	R/W		
0×68	Run mode X	R/W	Run mode X, if X! =0 loads to mode0	
0×69	feedback	R	In the state of 0×FF feedback, the clamping jaw stops and the position is not within the set feedback position In the feedback state of 0×F0, the clamping jaw stops and the position is within the set feedback position In the feedback state of 0×0F, the clamping jaw moves and its position is not within the set feedback position In the feedback state of 0×00, the clamping jaw moves and its position is within the set feedback position	

0×6A	Now position_L	R	Current position of clamping jaw	
0×6B	Now position_H	R		
0×6C	error	R	Error state feedback	error : bit7 EEPROM ERR error : bit6 Voltage ERR error : The power on bit1 is not standard error : Whether bit0 is within the feedback range
0×6D	Voltage	R	Current voltage	
0×A0	Power on gripper check	R/W	The on-power calibration is triggered, and the value assigned after each re-power-on is 0×55 for open calibration and 0×AA for closed calibration. After power-on, only one kind of calibration will be performed, and only one will be performed	Prevent misoperation only single register operation is allowed Data len = 1
0×A1	EEPROM Rest	R/W	Write 0×A5 to EEPROM reset three times in a row	Prevent misoperation only single register operation is allowed Data len = 1
0×A2	Block write EEPROM	R/W	Write 0×A5 to EEPROM 3 times in a row 0×00~0×55	Prevent misoperation only single register operation is allowed Data len = 1
0×A3	Soft restart	R/W	0×A5 was written to the software reset three times in a row.	Prevent misoperation only single register operation is allowed Data len = 1

Note: After each power-on, the A0 register needs to be operated to trigger the calibration before the gripper can move normally. After power-on, only one type is executed and only one time is needed.

Examples of gripper commands:

Query ID : 0x48 0x49 0x74 0xff 0x00 0x00 0x01 (0x78)

Closed calibration:0x48 0x49 0x74 0x01 0x01 0xA0 0x01 0xAA (0x35)

Open calibration:0x48 0x49 0x74 0x01 0x01 0xA0 0x01 0x55 (0xC6)

Inquiry voltage:0x48 0x49 0x74 0x01 0x00 0x6D 0x01(0xA3)

Vigorously open at high speed: 0x48 0x49 0x74 0x01 0x01 0x60 0x09 0xE8 0x03 0xff 0x00 0x00 0xFF 0x00 0x00 (0x2A)

Vigorously close at high speed: 0x48 0x49 0x74 0x01 0x01 0x60 0x09 0x64 0x00 0xff 0xff 0x00 0x00 0xFF 0x00 0x00 (0x09)

Read current position: 0x48 0x49 0x74 0x01 0x00 0x6A 0x02 (0xC1)

The brackets are checksum

■ ■ The second part Introduction electrical wiring

Panel wiring is shown in the figure below

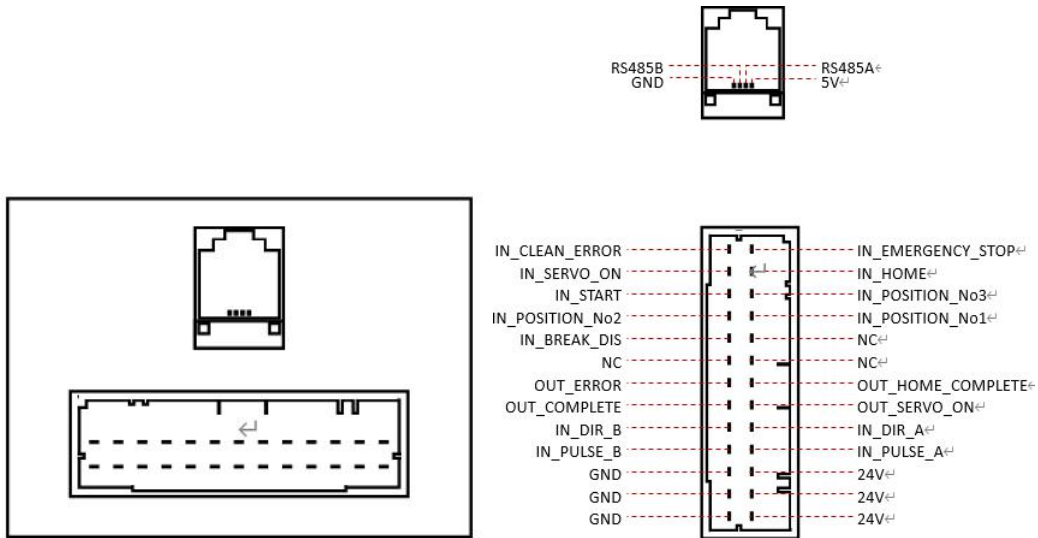

Serial number	The name of the	Input/output	role
1	IN_EMERGENCY_STOP	The input	When the pin is suspended or +24V, it has no effect; When the pin is 0V, the motor stops abruptly.
2	IN_CLEAN_ERROR	The input	When the pin is suspended or +24V, it has no effect; Clear all recoverable errors when the pin is 0V, and clear OUT_ERROR pin output.
3	IN_HOME	The input	When the pin is suspended or +24V, it has no effect; When the pin is 0V, the cylinder performs a back to origin operation (no position sensor, internal recording origin).
4	IN_SERVO_ON	The input	When the pin is suspended or +24V, the servo motor is in the non-enabled state; When the pin is 0V, the servo motor is in the enabled state
5	IN_POSITION_No3	The input	When the pin is suspended or +24V, it has no effect; When the pin is 0V, the cylinder moves to the internal record point 3, please ensure that the position is valid. It can be operated by the upper computer software provided by our company through the suggestion of the configuration of 485.
6	IN_START	The input	When the pin is suspended or +24V, no external position signal is received. When the pin is 0V, the cylinder receives the external motion state.
8	IN_POSITION_No2	The input	Movement to internal recording point 2, performance is the same as 5 feet.
9	IN_BREAK_DIS	The input	Release internal lock, invalid on current single axis (no internal lock).
10	NC		No effect please do not connect
11	NC		No effect please do not connect
12	NC		No effect please do not connect

14	OUT_ERROR	The output	24V: the electric cylinder is abnormal, the specific ERROR can be read through the 485 bus, and some errors can be cleared through pin 2.0V: the cylinder is normal.
15	OUT_SERVO_ON	The output	+24V: the servo motor is in the enabled state; 0V: the servo motor is not enabled
16	OUT_COMPLETE	The output	+24V: the cylinder has moved to the set position (while walking 5,7 and 8 feet, the target position is obtained at the same time)0V: the cylinder has not moved to the set position
17	IN_DIR_A	The input	The differential a-phase input level is 26LS31;Input for direction in pulse direction mode.Input for one of the pulses in pulse modelt can be operated by the upper computer software provided by our company through the suggestion of 485 configuration.
18	IN_DIR_B	The input	Differential b-phase input of 17 feet.
19	IN_PULSE_A	The input	The differential a-phase input level is 26LS31;Pulse input in pulse direction mode.Input for one of the pulses in pulse modelt can be operated by the upper computer software provided by our company through the suggestion of 485 configuration.
20	IN_PULSE_B	The input	Differential b-phase input of 17 feet.
21、23、25	24V	The input	24V power input, 24V+-10%
22、24、26	0V	The input	24V power input, 0V

Pin structure:

1~9 pins are NPN type input and are not separated from the power supply 0V;

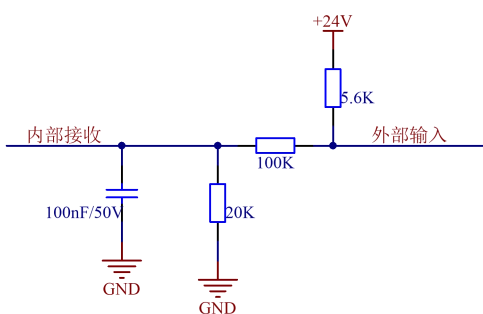

13~16 feet are push-pull output pins

Can output 0V 24V output capacity of 20mA. Can push the input of PLC directly, can't push the relay.

The differential input is from 17 to 20 feet, and the input level refers to 26LS31 output. The power input is 24V power input, and the power can be selected according to the actual use of the customer. It is recommended to reserve at least 50% of the power in case of a large load to meet the demand for high performance.

The eia-485 interface is the standard eia-485 electrical interface through which the electric cylinder can be fully controlled. It can only supply power to the electric cylinder, and then control the electric cylinder through the eia-485 interface. And configuration.

The internal integrated battery (can be replaced), it is recommended to replace once every 2 to 3 years, the zero will be lost when the replacement, need to pass 485 to recalibrate the zero.

Internal integration of servo brake resistance, customers do not need external brake resistance.

All signal lines (including eia-485) are not isolated from the power line. If necessary, please isolate them by yourself.

■ ■ Q & A

1.The rotation has a concentricity requirement, so both sides are close to each other. Does it stop at the middle position every time?

A: Yes, there is a symmetry error that smaller than 0.1mm, and the repeated accuracy is $\pm 0.02\text{mm}$.

2.Does the product include a front-end clamping part?

A: No. Users need to design this part themselves based on the objects they need to clamp. In addition, Hui Ling will also provide a small library of clamps. Please contact sales personnel for assistance.

3.Where is the controller? Does it need the extra pay?

A: Built-in. No extra pay. It is covered in the cost of clamp.

4.Can it support one-finger movement?

A: No, such product is still under development. Please contact the sales personnel for details.

5.What is the operating speed of Z-EFG-8 and Z-EFG-20?

A: Z-EFG-8 goes one way in one direction, with 0.3s, and back and forth in 0.6s; Z-EFG-20 goes one way in one direction, takes 0.45s, and goes back and forth for 0.9s.

6.What is the clamping force of Z-EFG-8 and Z-EFG-20? How to adjust?

A: The clamping force of the Z-EFG-8 is 5-30N. The Z-EFG-8 can be manually adjusted with the actuator on the side of the electric gripper or by software adjustment via the wiring in analog mode. The clamping force of the Z-EFG-20 is 80N, and the clamping force can be adjusted by adding a controllable deformation material in front of the gripper, which can be obtained according to the corresponding curve of deformation and force.

7.How to adjust the clamping stroke of Z-EFG-8 and Z-EFG -20?

A: Z-EFG-8 does not can't adjust the stroke. The 200 pulses of the Z-EFG-20 correspond to a 20mm stroke and 1 pulse corresponds to a 0.1mm stroke.

8.What happens if I send 300 impulses?

A: The extra pulses will not be executed and there will be no effect.

9.What happens if I send 200 impulses but the gripper catches objects with 100 pulses? Will it stop and will the left 100 pulses still be sent?

A: It will stop and after it loosens, the pulses will continue to be sent.

10.How to determine that the gripper clamp objects?

A: For the Z-EFG-8, the gripper will stops if clamps objects. When the gripper stops, the signal output line (black line) will output 3.3V and the LED will light up. The gripper with force feedback to determine if the object is successfully clamped is under development. Please contact sales personnel for the development progress. For Z-EFG-20, the number of feedback pulses reflects the position of the gripper, so the users can determine whether the object is clamped according to the feedback pulse counting.

11. Is the Z-EFG series of motor-driven gripper waterproof? A: No. Contact sales personnel for special requirements.

12. Is it possible to use Z-EFG-8 or Z-EFG-20 grippers to clamp objects larger than 20mm?

A: Yes, 8mm and 20mm refers to the effective stroke, not the size of the object that will be clamped. The maximum to minimum size difference of the gripped object is within 8mm. All of them can be gripped by Z-EFG-8. Z-EFG-20 can be used to clamp objects with a maximum to minimum size difference within 20mm.

13. If the machine keeps working, will the motor of the gripper be overheated?

A: Through our professional test, if Z-EFG-F keeps working under around 30°C, the temperature of its surface will not be over 50°C.

14. Can I set the air duct internal?

A: We will set the place for internal air duct in next version.

15. Can I install the Z-Arm inverted or paralleled?

A: Z-Arm could not be installed inverted or paralleled for now.

16. Can Z-Arm controlled by PLC?

A: Yes, you could use PLC to control it.

17. Can I use the APP in Android?

A: The APP on Android is used to set the Z-Arm IP address through Wifi, it could not drive the Z-Arm to move, but you could use Hitbots software and SDK libraries on Windows.

18. Which version of Windows that I could use Hitbot software or SDK libraries?

A: They support WIN7 and WIN10, but WIN XP and WIN8 are unknown.

19. Can I secondary develop a program to control multiple Z- Arms?

A: Yes, Z-Arms could be controlled by one program.

20. How many Z-Arms I could control at the same time with secondary development?

A: The max number is 255.

21. Can I control several Z-Arms with Hitbots software?

A: For now, one hitbot application sample could control one Z- Arm, if there were several Z-Arms to control, you could set more hitbot application sample, and more functions are developing.

22. What is the use for server. exe?

A: Server. exe is a server program, it plays a role as a message transmission between robot and program.

23. Could Z-Arm work collaborative with machine vision system?

A: For now, Z-Arm could with machine vision system directly, but users could make the secondary development on sending some data from vision system, and control Z-Arm through the relative libraries.

24. How to check whether object is gripped or not?

A: It could be checked through the setting of position and feedback to know whether it gripped the object with Z-EFG-20, it doesn't work for Z-EFG-8.



HITBOT

IMTEC s. r. o.

Kadnárova 19, 83152 Bratislava Slovakia (EU) +421 90561 6753

